

MONTAGEANLEITUNG

ASSEMBLY INSTRUCTIONS

NOTICE DE MONTAGE

MONTAGEHANDLEIDING

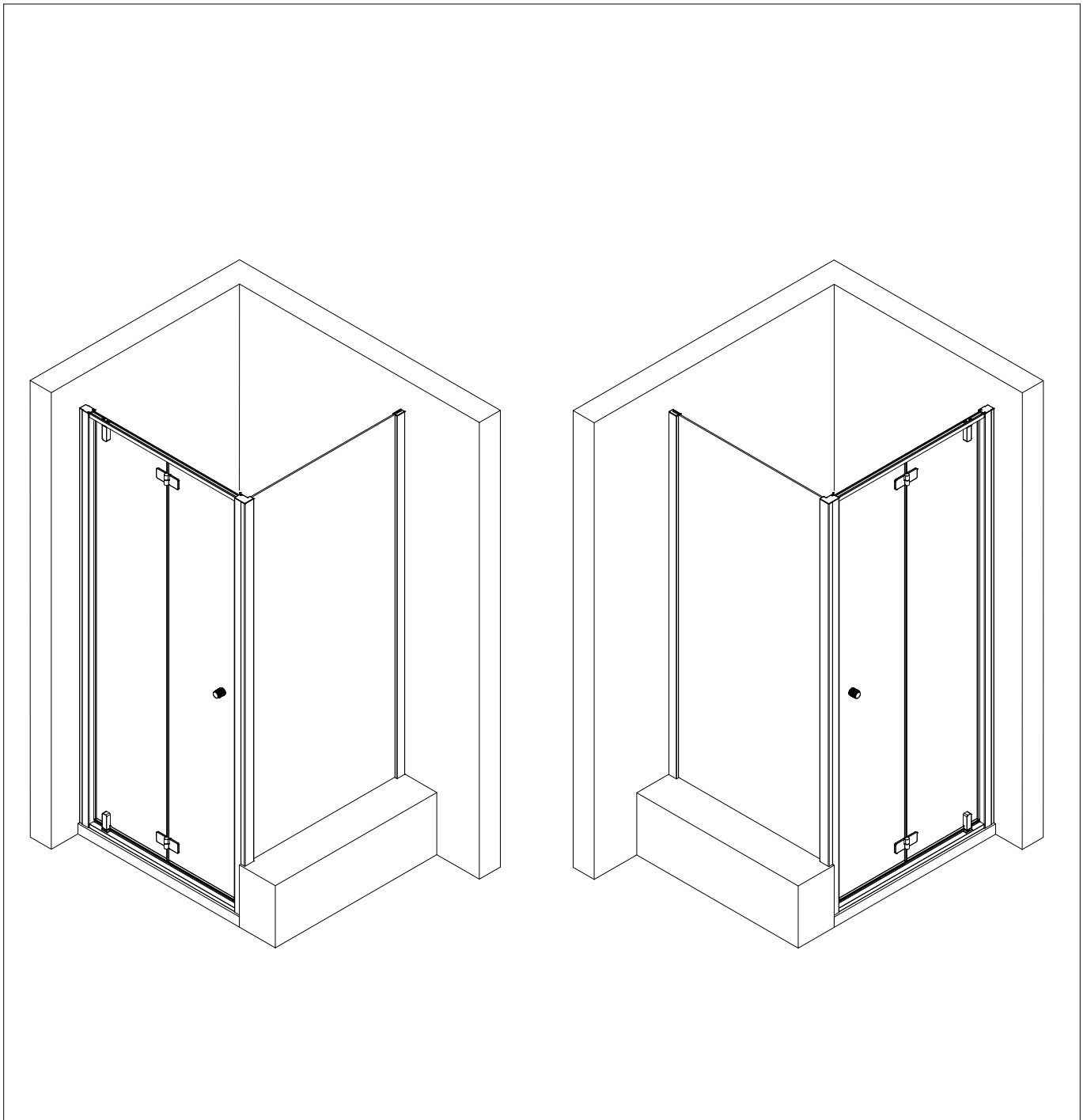



SICHERHEITSHINWEISE / SAFETY INSTRUCTIONS CONSEILS DE SÉCURITÉ / VEILIGHEIDSAANWIJZINGEN



de Glaskanten schützen

en Protect glass edges

fr Protégez les bords du verre

nl Glasranden beschermen

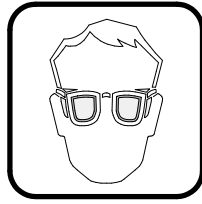

de Schutzbrille tragen

en Wear safety goggles

fr Portez des lunettes de protection

nl Veiligheidsbril dragen

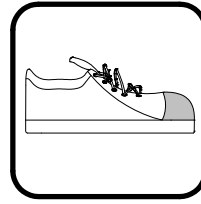

de Sicherheitsschuhe tragen

en Wear safety shoes

fr Portez des chaussures de sécurité

nl Veiligheidsschoenen dragen

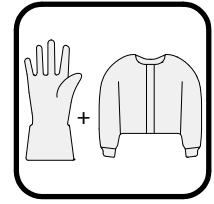

de Lange Handschuhe und langärmelige Kleidung tragen

en wear long gloves and long-sleeved clothing

fr portez des gants longs et des vêtements à manches longues

nl Draag lange handschoenen en kleding met lange mouwen

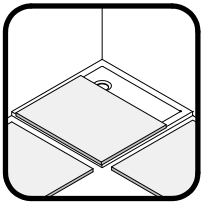

de Decken im Arbeitsbereich und dessen Umfeld auslegen

en Cover the shower tray and its area completely

fr Couvrez complètement le bac de douche et ses environs

nl Dekens op de douchebak en de omgeving leggen

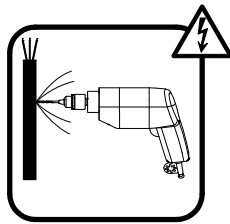

de über die Lage der Stromleitung informieren

en get information about the location of the power line

fr Informez-vous sur l'emplacement de la ligne électrique

nl Informeren over de locatie van de hoogspanningslijn

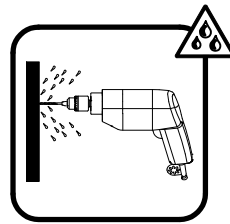

de über die Lage der Wasserleitung informieren

en get information about the location of the water pipe

fr Informez-vous sur l'emplacement de la ligne d'eau

nl Informeren over de locatie van de waterleiding

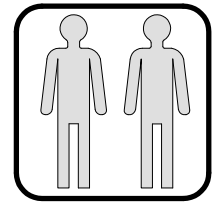

de Empfohlene Montage mit 2 Personen.

en Assembly recommended with 2 persons

fr Montage recommandé avec 2 personnes

nl Aanbevolen montage met 2 personen

HINWEIS / NOTE / NOTE / NOOT

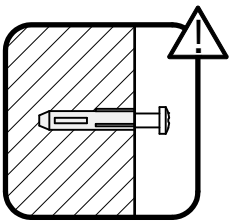

de Vor der Montage die Beschaffenheit des Mauerwerks überprüfen. Gegebenenfalls ist das im Lieferumfang enthaltene Befestigungsmaterial nicht für die Befestigung geeignet.

en Check the condition of the masonry before installation. If applicable, the fixing material included in the scope of delivery is not suitable for mounting.

fr Vérifiez l'état de la maçonnerie avant le montage. Le cas échéant, le matériel d'approvisionnement compris dans la livraison n'est pas adapté à la fixation.

nl Controleer de toestand van het metselwerk voor de installatie. Indien gewenst is het bij de levering inbegrepen bevestigingsmateriaal niet geschikt voor montage.

de Die Aufstellfläche der Duschkabine muss eben sein.

en The installation surface of the shower enclosure must be level.

fr La surface d'installation de la cabine de douche doit être plane.

nl Het montagevlak van de douchewand moet waterpas zijn.

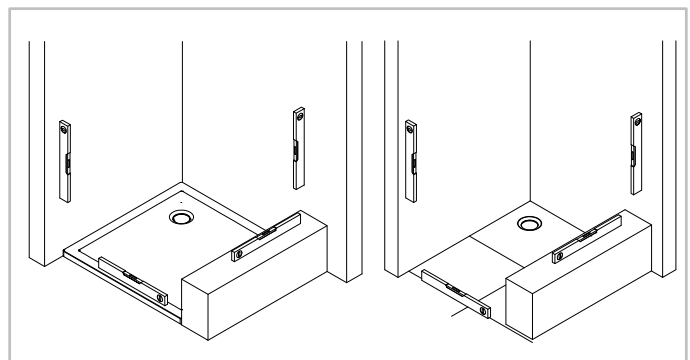

AUFBAUART / ASSEMBLY SITUATION / TYPE DE MONTAGE / ASSEMBLAGE SITUATIE

de Bei der Montage der Duschkabine gibt es zwei Aufbauarten: Aufbau **a** und **b**
In dieser Montageanleitung wird der Aufbau **a** dargestellt. Die Montageschritte für den Aufbau **b** sind spiegelbildlich durchzuführen.

en There are two types of installation for the shower enclosure: **a** and **b**
Situation **a** is described in this assembly instruction. The assembly steps for situation **b** must be carried out in mirror image.

fr Il y a 2 possibilités de monter la paroi de douche : **a** et **b**
La version **a** est illustrée dans la notice de montage. Les étapes pour monter la version **b** sont inversées.

nl Er zijn twee soorten installatie voor de douchewand: **a** en **b**
Montage **a** wordt getoond in deze montagehandleiding. De montageschappen voor installatie **b** moeten in spiegelbeeld worden uitgevoerd.

a

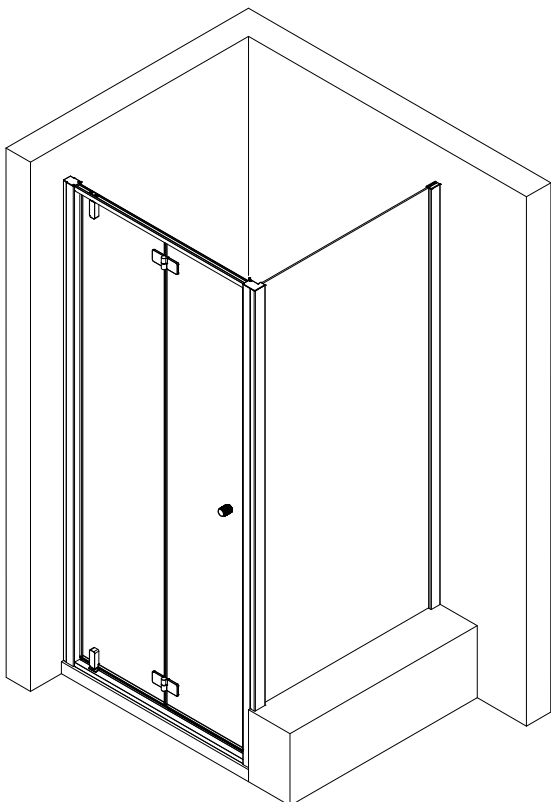

b

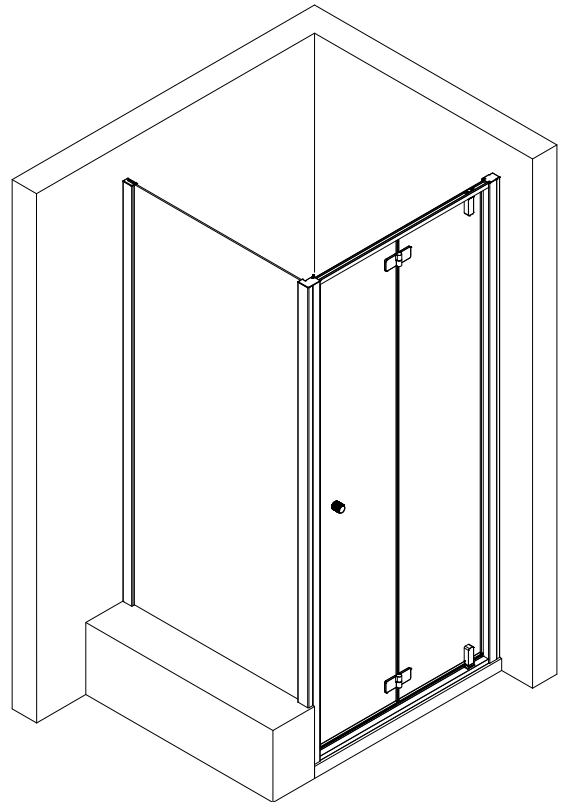

MAßE / DIMENSIONS / DIMENSIONS / AFMETINGEN

- de** Prüfen, ob die gemessenen Maße innerhalb der Tabellenwerte (A, B) liegen, damit die Duschkabine problemlos, anhand der Montageanleitung aufgebaut werden kann.
- en** Check whether the measured dimensions are within the table values (A, B), so that the shower enclosure can be assembled without any problems using the assembly instructions.
- fr** Vérifier que les dimensions mesurées se situent dans les valeurs du tableau (A, B), afin que la cabine de douche puisse être montée sans problèmes en suivant les instructions de montage.
- nl** Controleer of de gemeten afmetingen binnen de tabelwaarden (A, B) vallen, zodat de douchewand zonder problemen met behulp van de montagehandleiding kan worden gemonteerd.

de Montage auf Duschwanne (Maße des installierten Duschbeckens)

en Mounting on shower tray (Dimensions of the installed tray)

fr Montage sur receveur de douche (Dimensions du mur au bord d'extérieur du receveur)

nl Montage op douchebak (Afmetingen van de ingebouwde douchebak)

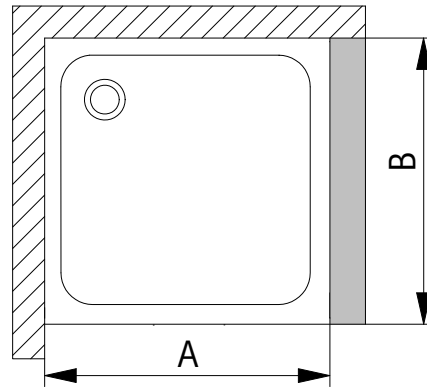

Duschwanne / shower tray receveur de douche / douchebak	A (Türseite / door side / côté porte / deur zijde)	B (Seitenwandseite / side of side panel / côté paroi / zijwand zijde)
800 mm	785 - 800 mm	785 - 805 mm
900 mm	885 - 900 mm	885 - 905 mm

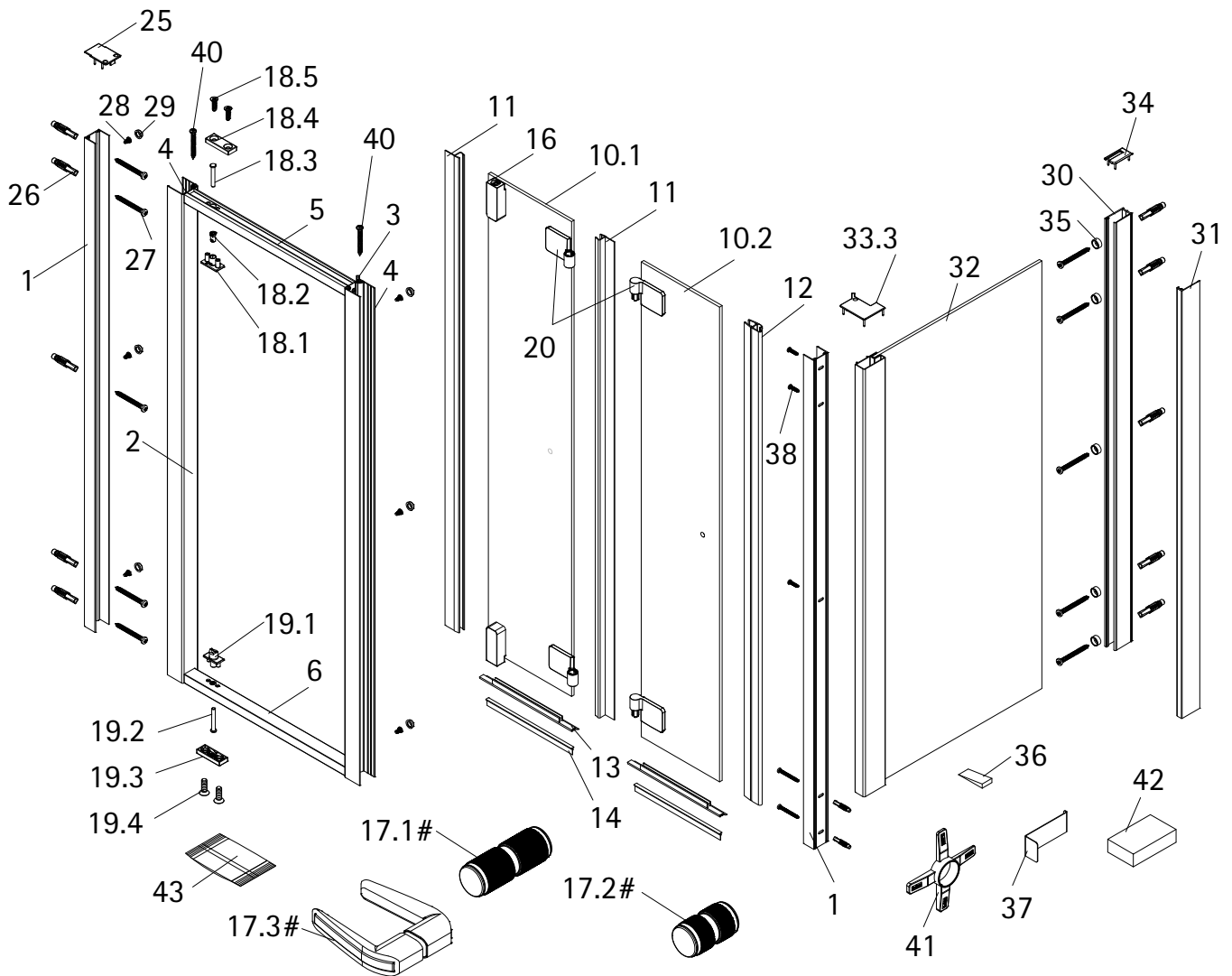

Pos.	Bezeichnung	Ersatzteil-Nr.	Preis	Pos.	Bezeichnung	Ersatzteil-Nr.	Preis
1	2x Wandanschlussprofil	E30230-5	Stück 91,10 €	19.3	1x Fixierung		
2	1x Anschlussprofil	E30252-1	Stück 57,60 €	19.4	2x Senkschraube M4 x 12 mm		
3	1x Magnetaufnahmeprofil	E30253-1	Stück 70,20 €	20	2x Scharnier komplett, Links	E100290-L-77	Stück 106,90 €
4	2x Abdeckprofil	E30254-1	Stück 38,70 €	2x	Scharnier komplett, Rechts	E100290-R-77	Stück 106,90 €
5	1x Rahmenprofil	E30240-7	Stück 70,20 €	25	2x Abdeckkappe	E30205-3	Set 12,50 €
6	1x Rahmenprofil	E30241-6	Stück 70,20 €	26*	15x Dübel		
10.1	1x Türscheibe Anschlagseite			27*	15x Schraube 4,2 x 45mm		
10.2	1x Türscheibe Schließseite			28*	6x Schraube 3,5 x 9,5mm		
11	2x h-Dichtung	E100072-6	Stück 26,10 €	29*	6x Abdeckkappe		
12	1x Magnetprofil 45°	E100055-1	Stück 36,20 €	30	1x Wandanschlussprofil	E100248-44-3	Stück 79,60 €
13	2x Wasserabweisprofil	E100058-6	Stück 24,10 €	31	1x Klemmprofil	E100249-44-2-6-13	Stück 37,70 €
14	2x Einschubdichtung	E100067-105-10	Stück 15,70 €	32	1x Seitenwandscheibe		
16	2x Drehlager an Tür, vormontiert	E100085-4	Stück 34,50 €	33.3	1x Abdeckkappe links/ rechts		
17.1#	1x Knopfgriff mit Puffer	E100140-34	Stück 55,50 €	34	1x Abdeckkappe, links/ rechts		
17.2#	1x Knopfgriff mit Puffer	E100140-83	Stück 55,50 €	35*	5x Glasschutz		
17.3#	1x Klinkengriff	E100140-86	Stück 86,90 €	36	1x Silikonkeil (6 Stück)	E100203	Set 17,80 €
18	1x Drehlager oben, komplett	E100086	Set 29,30 €	37	1x Demontagehebel	E100201-1	Stück 32,40 €
18.1	1x Lagerbuchse			38	3x Schraube 4,2 x 19mm		
18.2	1x Buchse			40	2x Schraube 3,9 x 38mm		
18.3	1x Stift, kurz			41	1x Montagehilfe	E100201-2	Stück 12,60 €
18.4	1x Fixierung			42	2x Montagehilfe	E100201-3	Set 12,60 €
18.5	2x Senkschraube M4 x 12 mm			43	1x Fettbeutel		
19	1x Drehlager unten, komplett	E100087	Set 29,30 €				
19.1	1x Gegenlager				* Montagezubehör	E30200-3	Set 17,80 €
19.2	1x Stift				# optional		

de Geben Sie bei farbigen Ersatzteilen den Farbcode mit an: 01 - aluminium | 68 - schwarz | 70 - mattweiß

en Please state the colour code for coloured spare parts: 01 - aluminium | 68 - black | 70 - matte white

fr Veuillez indiquer le code couleur pour les pièces de rechange colorées : 01 - aluminium | 68 - noir | 70 - blanc mat

nl Gelieve de kleurcode voor gekleurde onderdelen te vermelden: 01 - aluminium | 68 - zwart | 70 - mat wit

BENÖTIGTES WERKZEUG / TOOLS NEEDED
OUTILLAGE NÉCESSAIRE / BENODIGD WERKTUIG

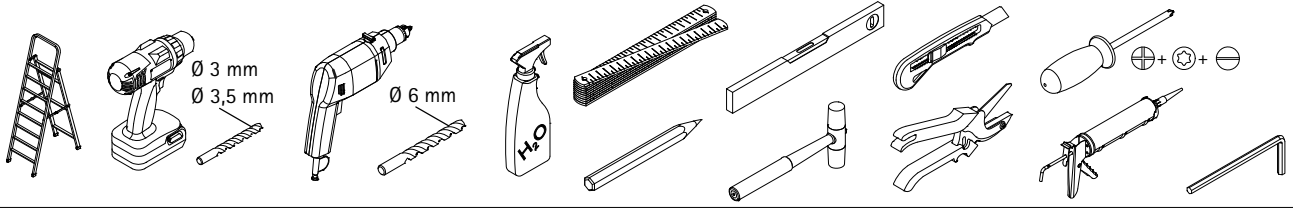

MONTAGE / ASSEMBLY / ASSEMBLAGE / ASSEMBLAGE

1

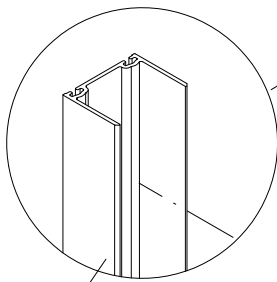
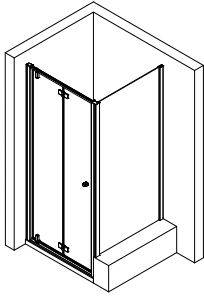

Pos. 1

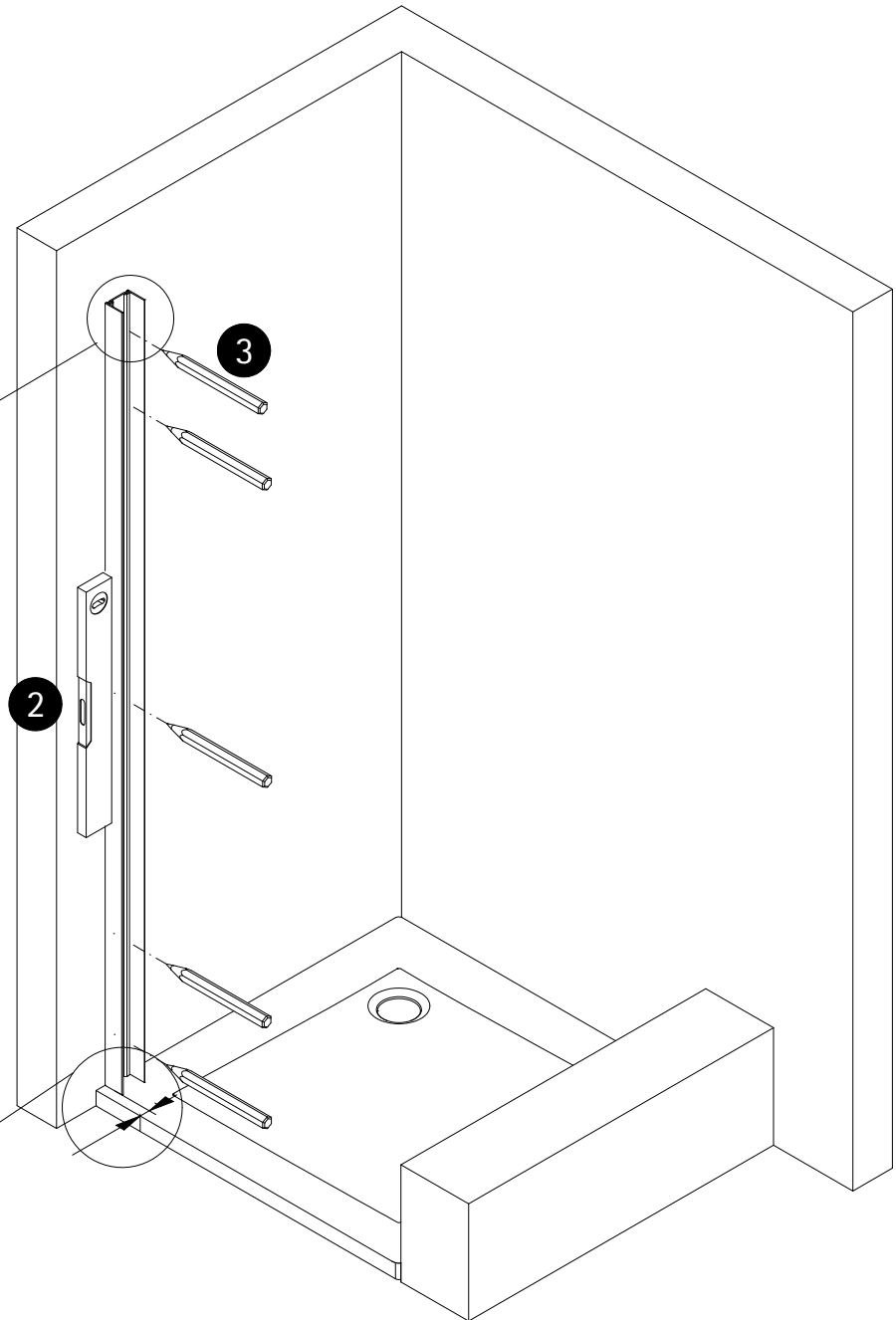
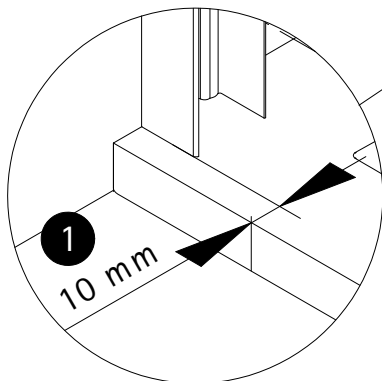

2

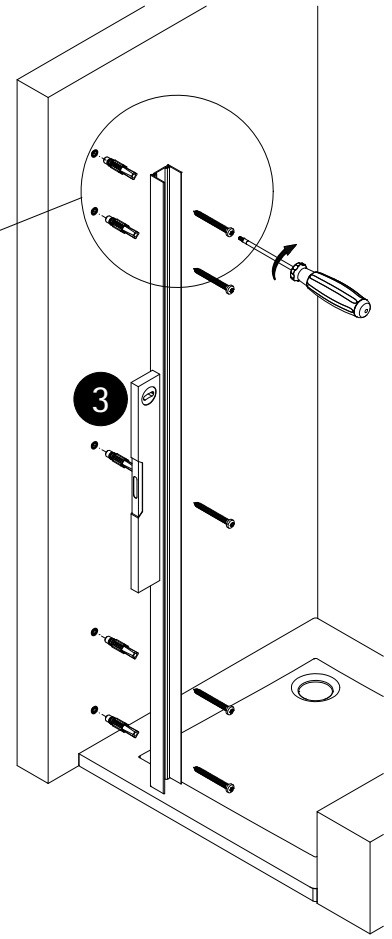
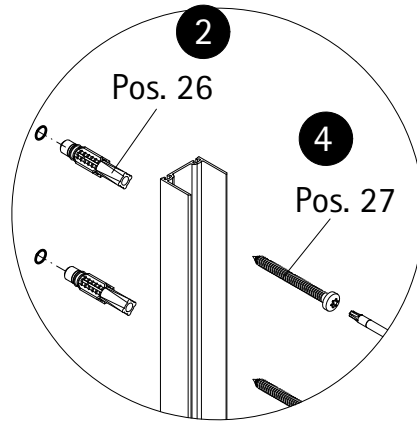
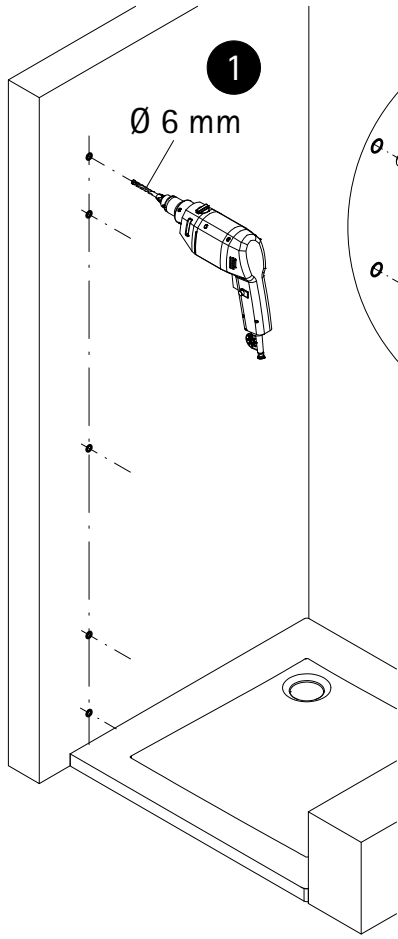
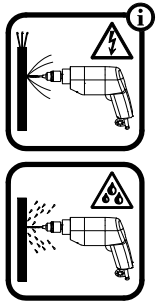

3

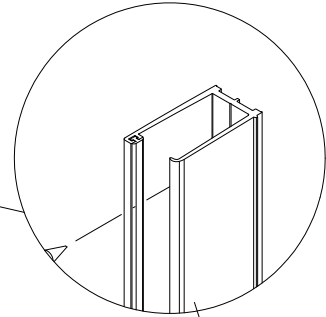
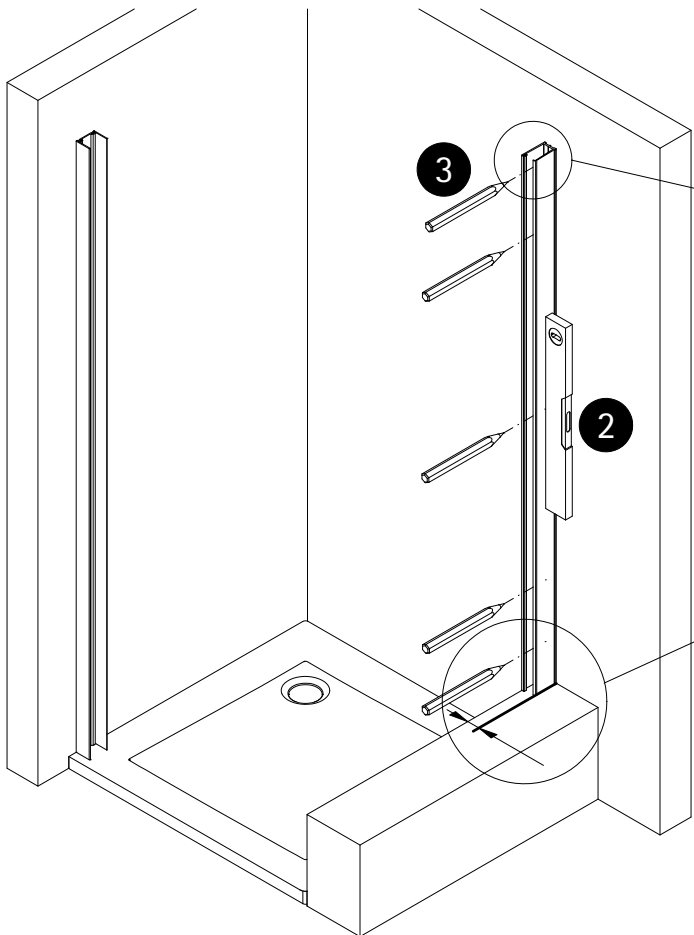

Pos. 30

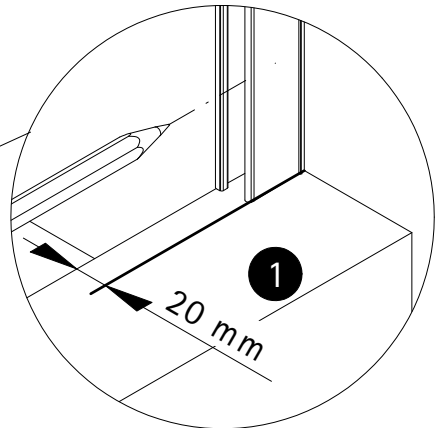

4

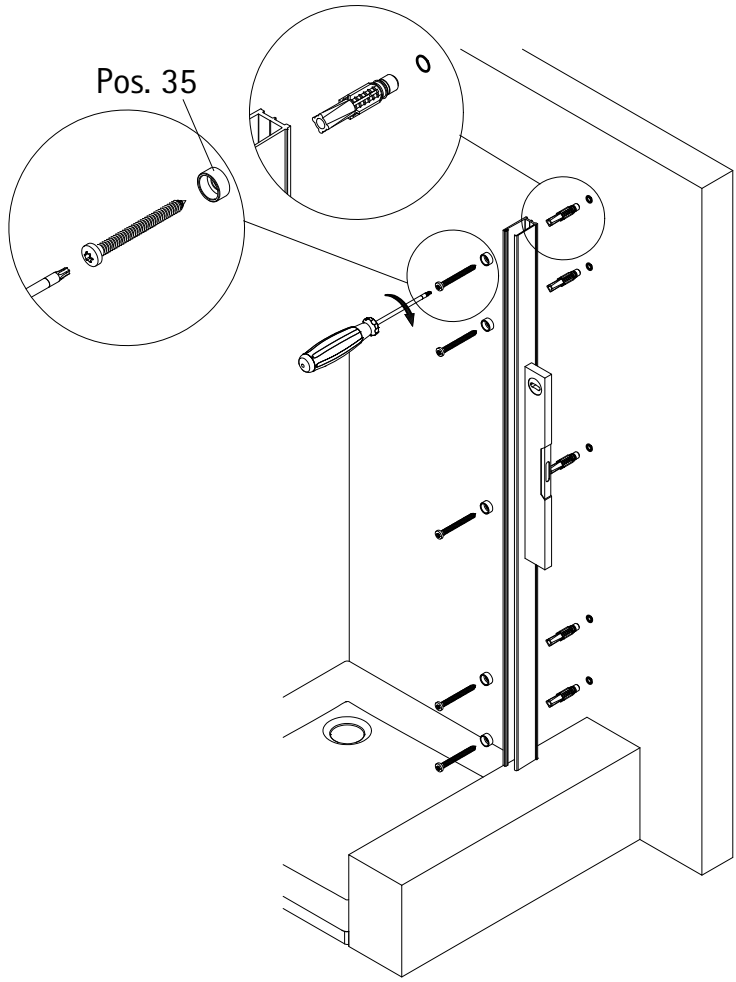
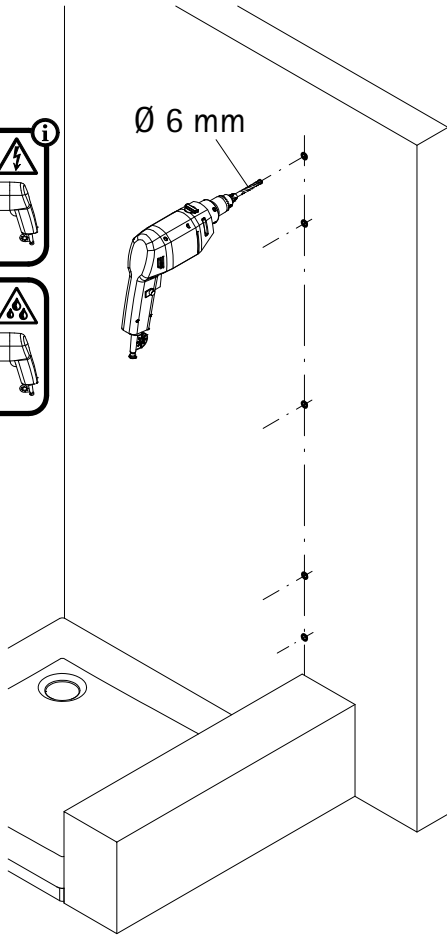
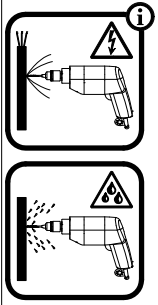

5

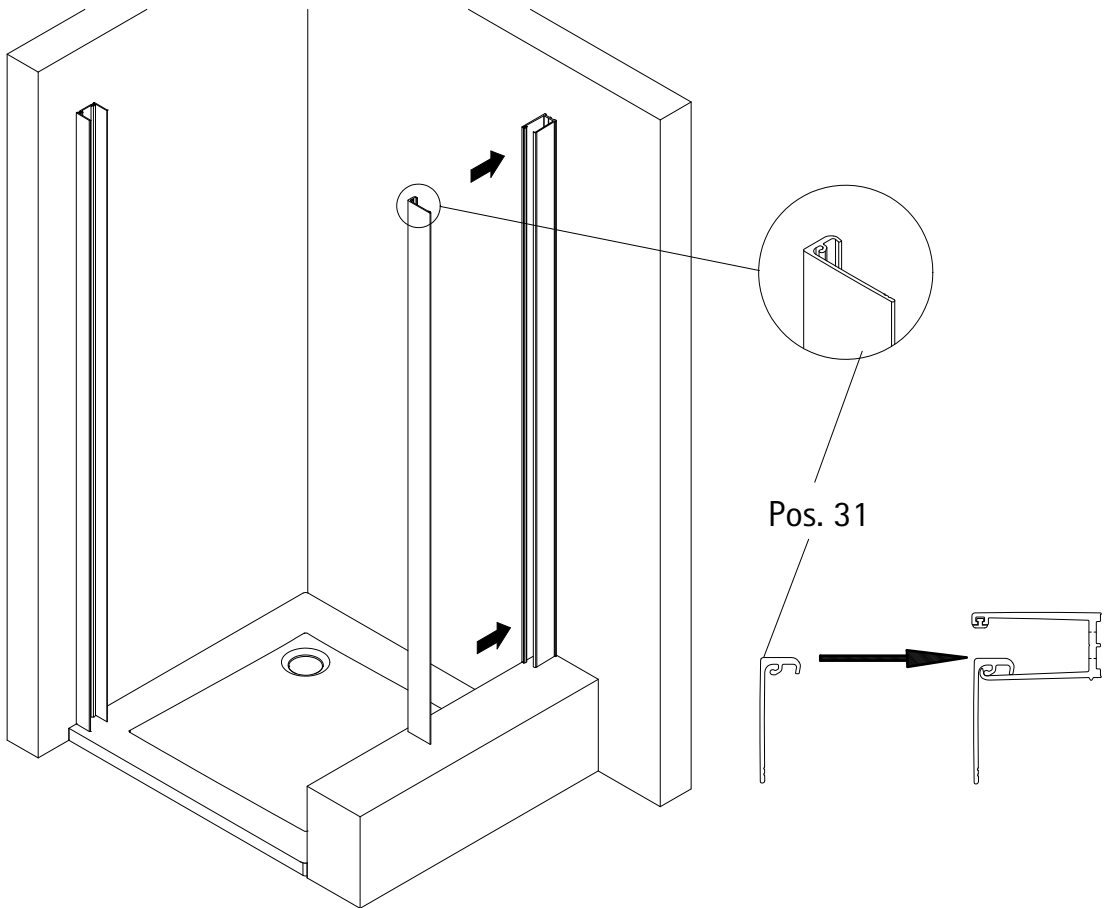

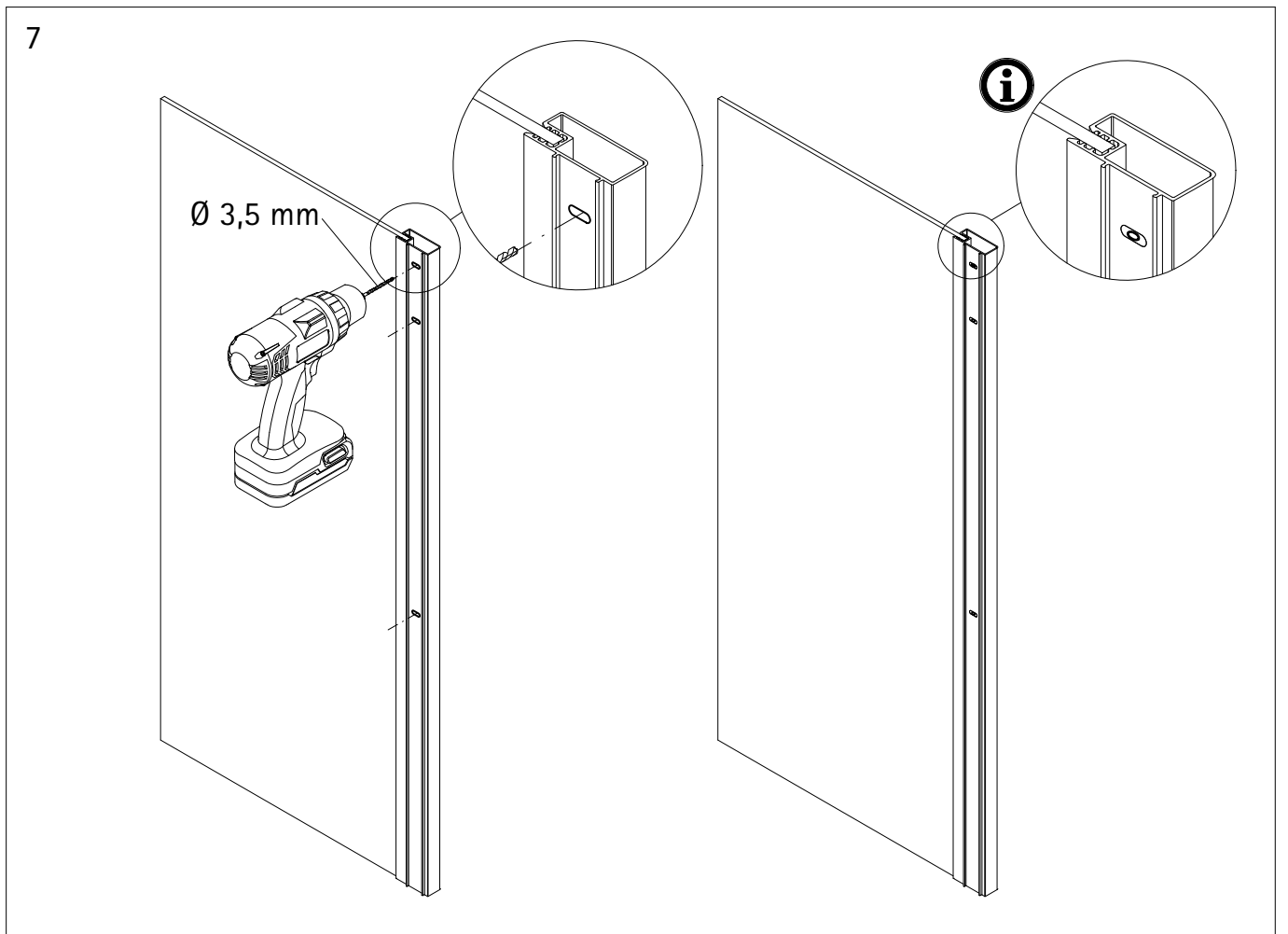
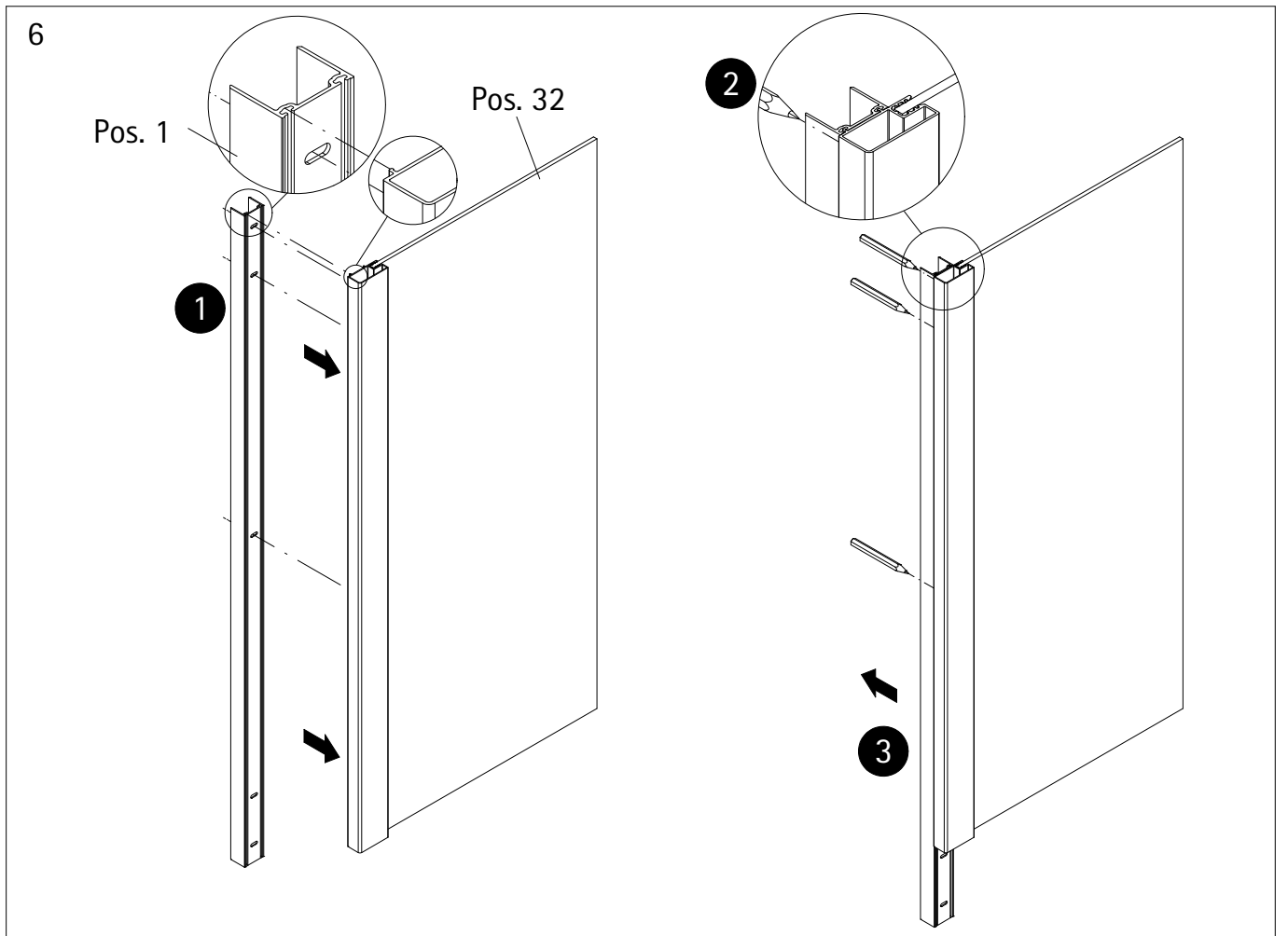

8

Pos. 38

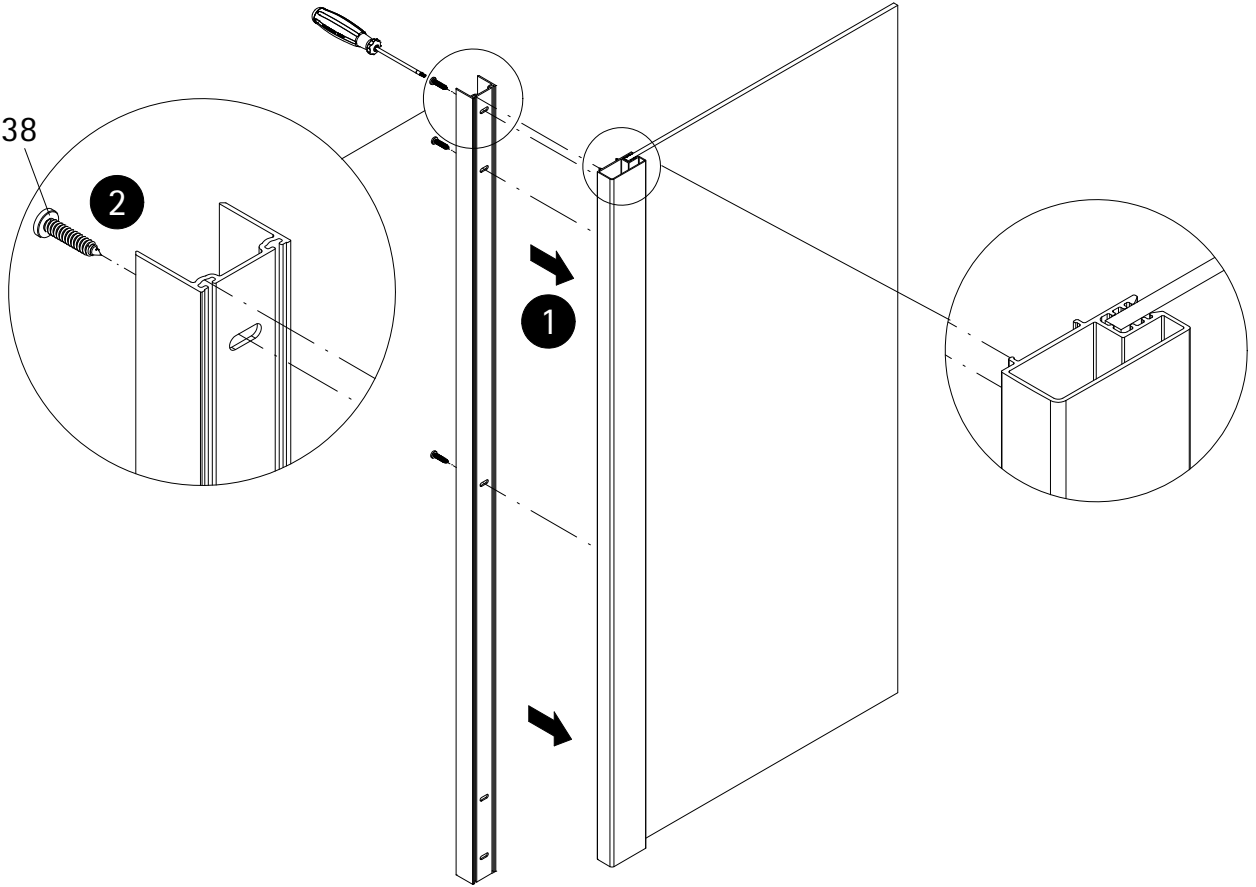

9

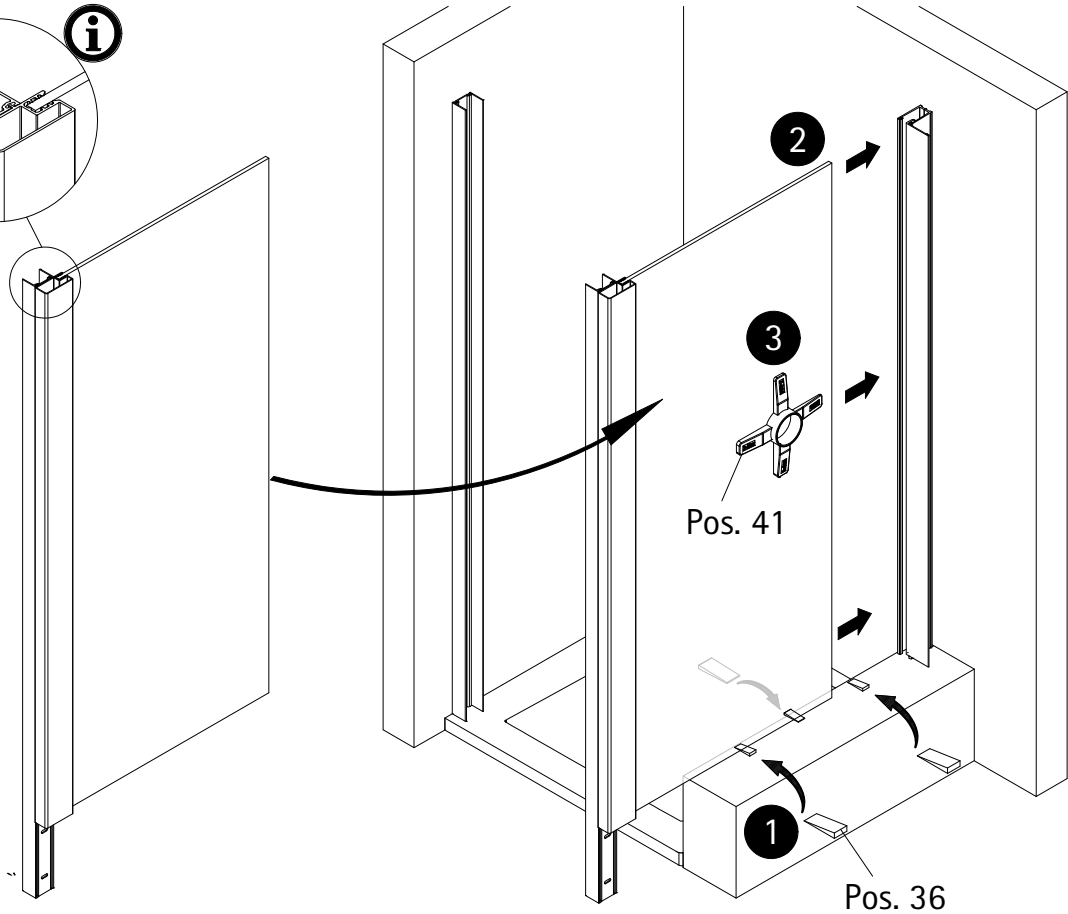
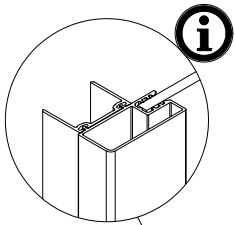

10

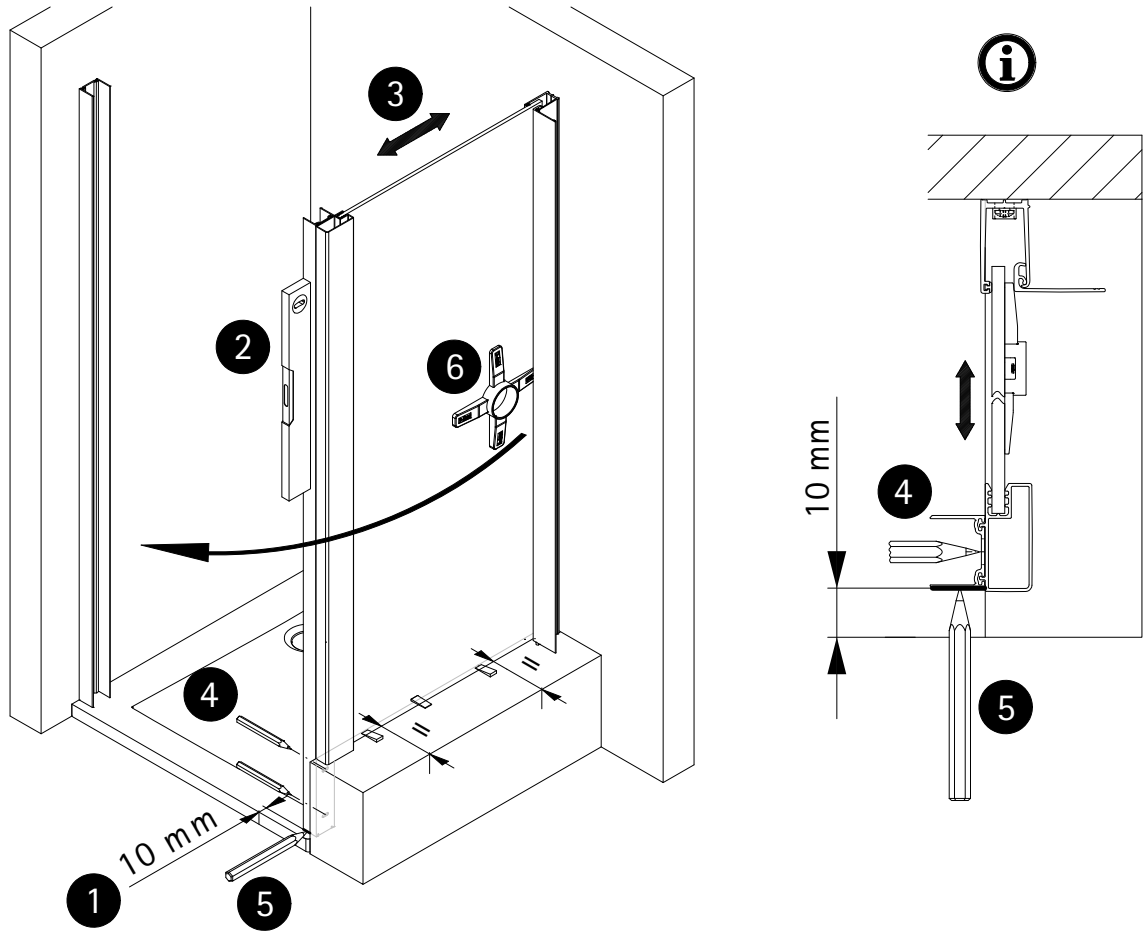

11

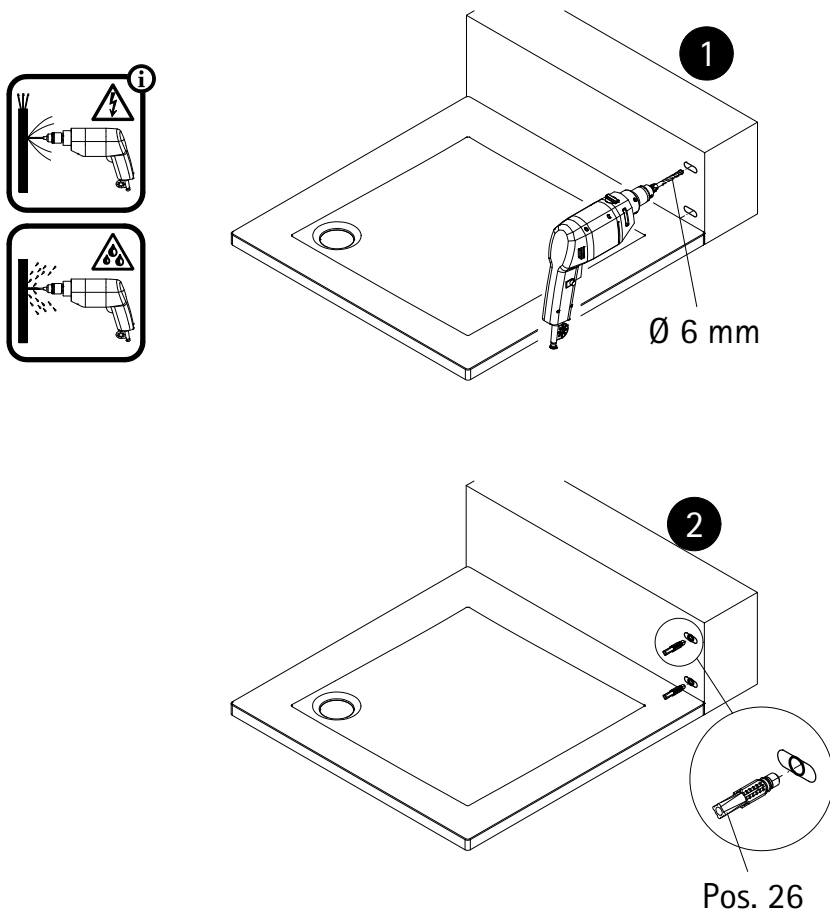

12

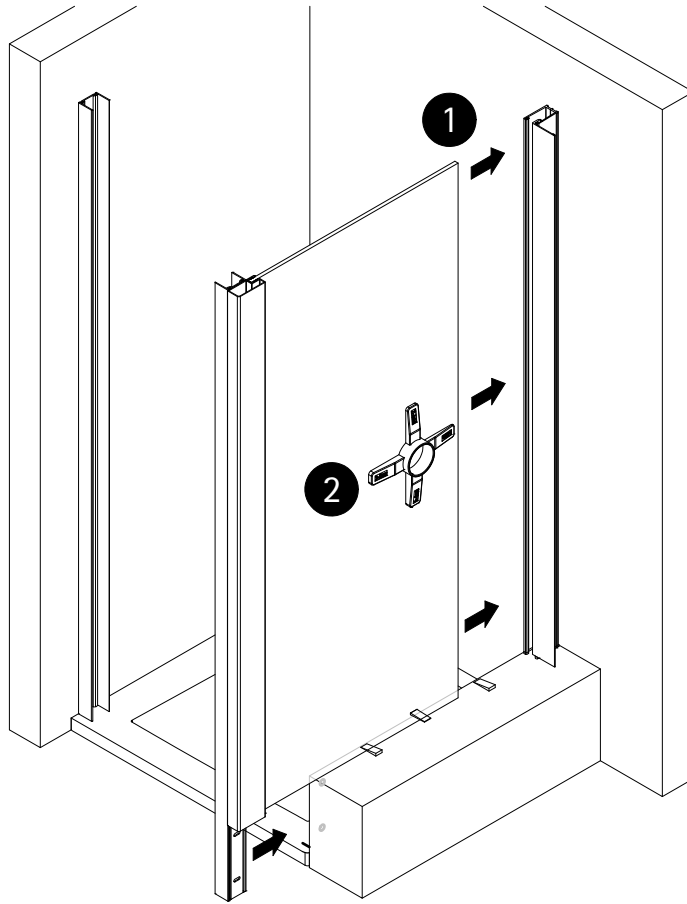

13

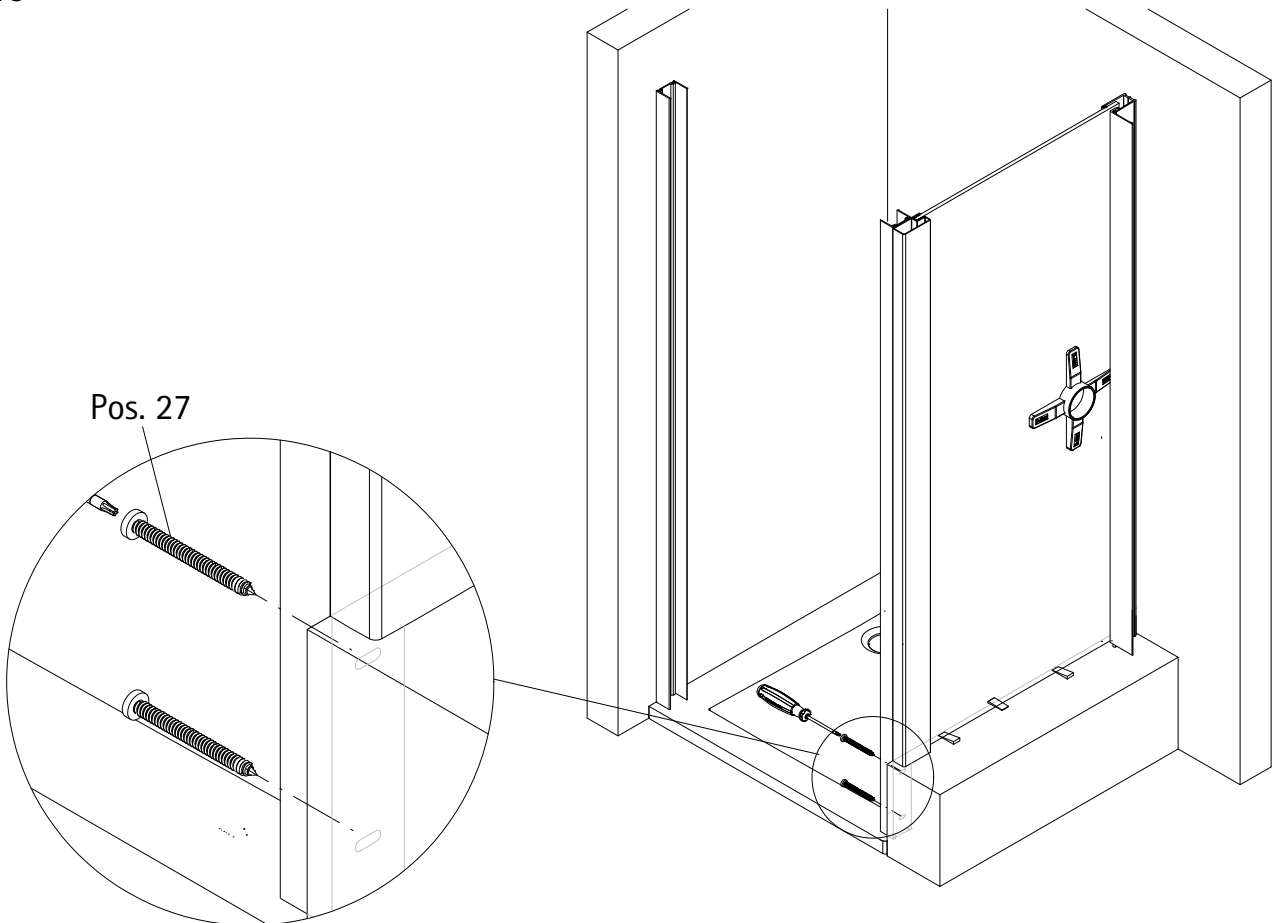

14

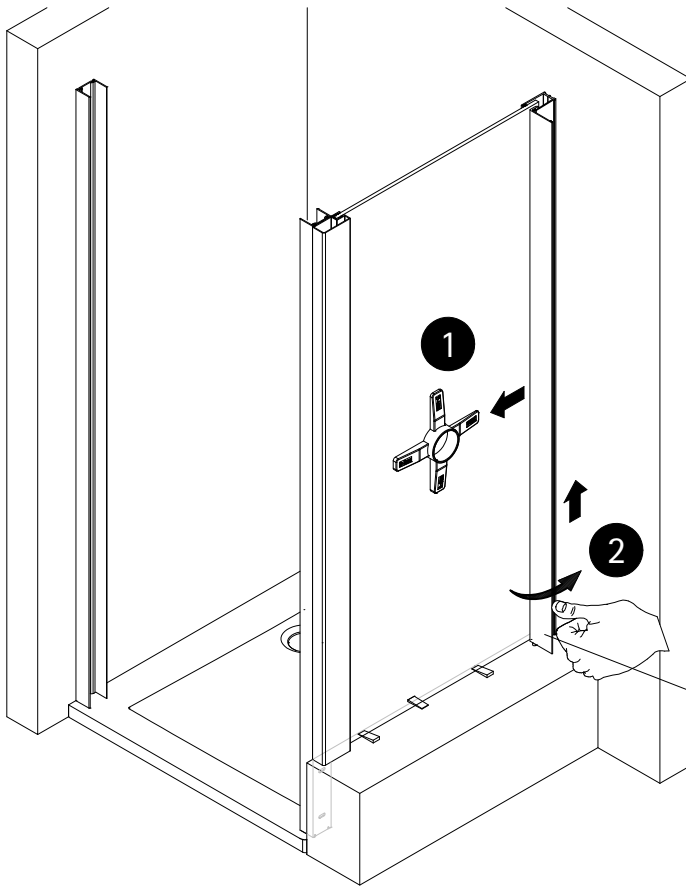

Hinweis auf Demontage
siehe Seite 27!
Note for disassembly
see page 27!
Remarque sur le démontage,
voir page 27!
Informatie over demontage zie
blz. 27!

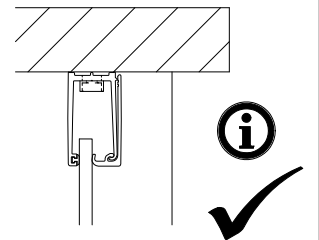
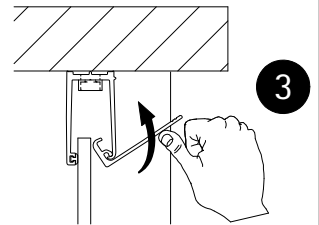
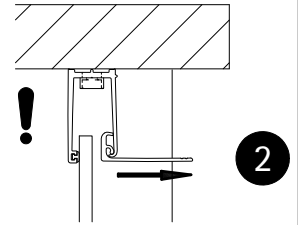

15

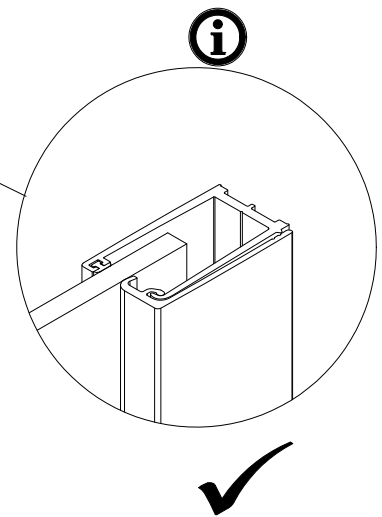
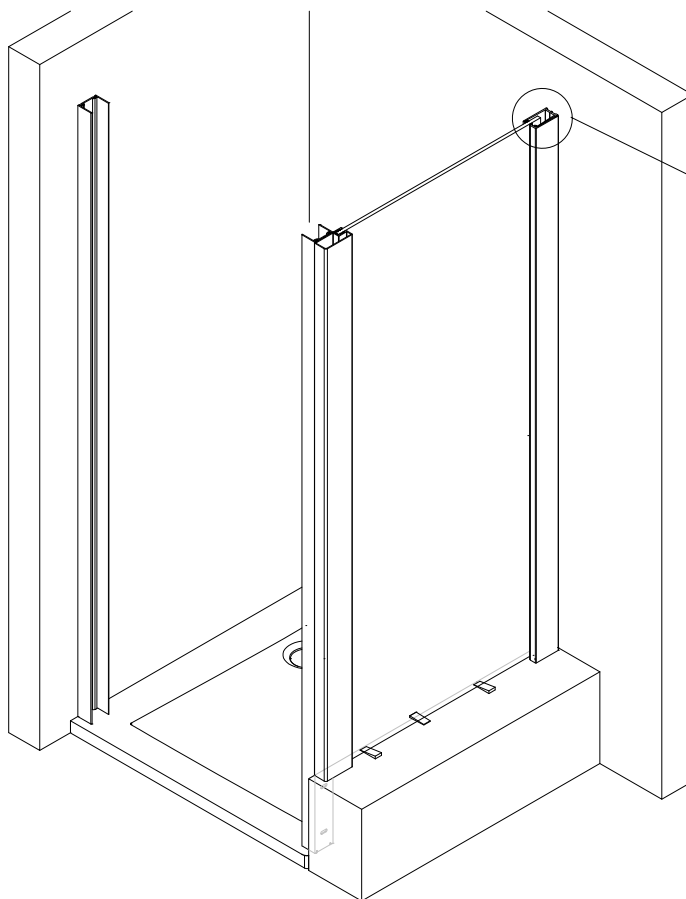

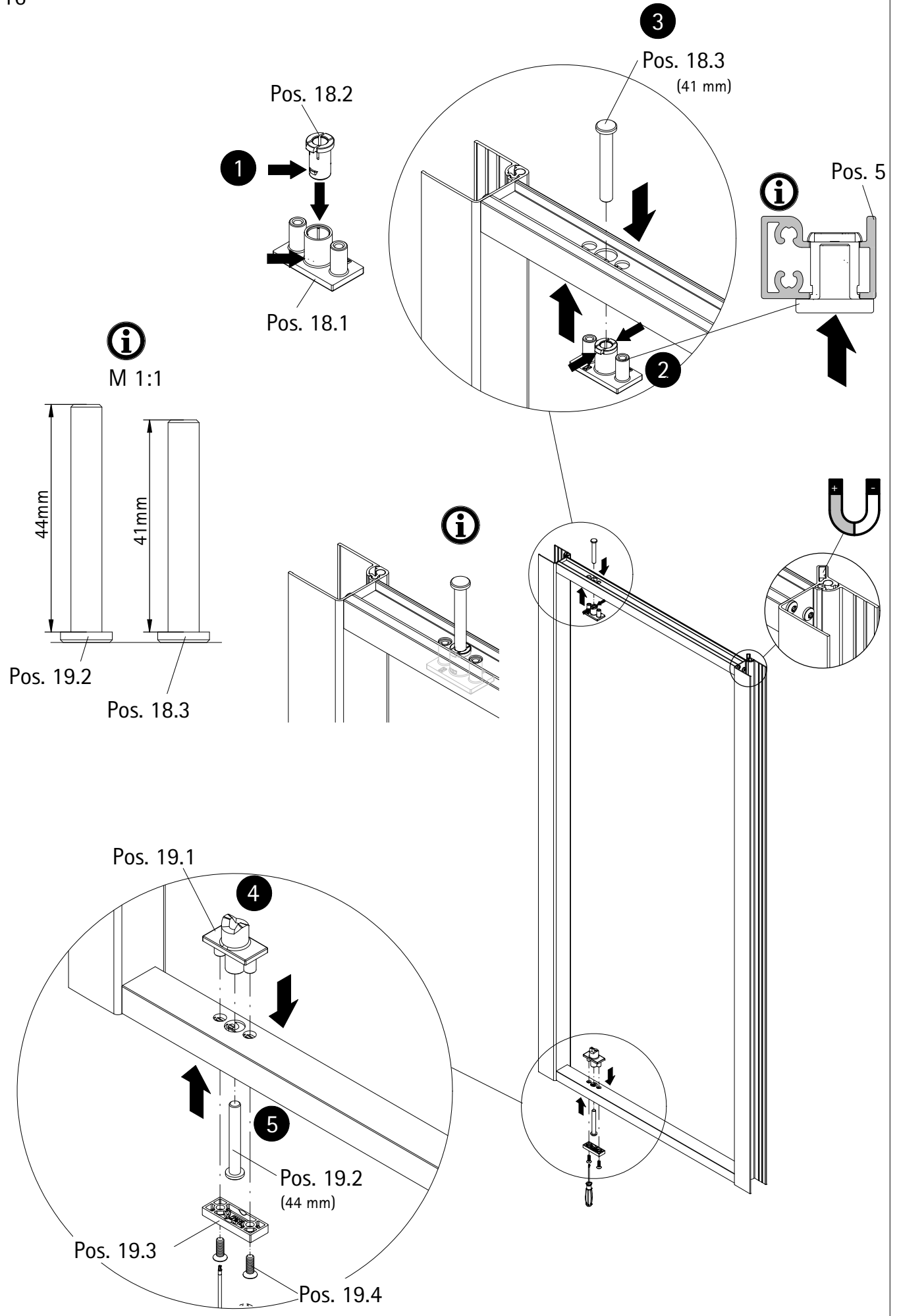

17

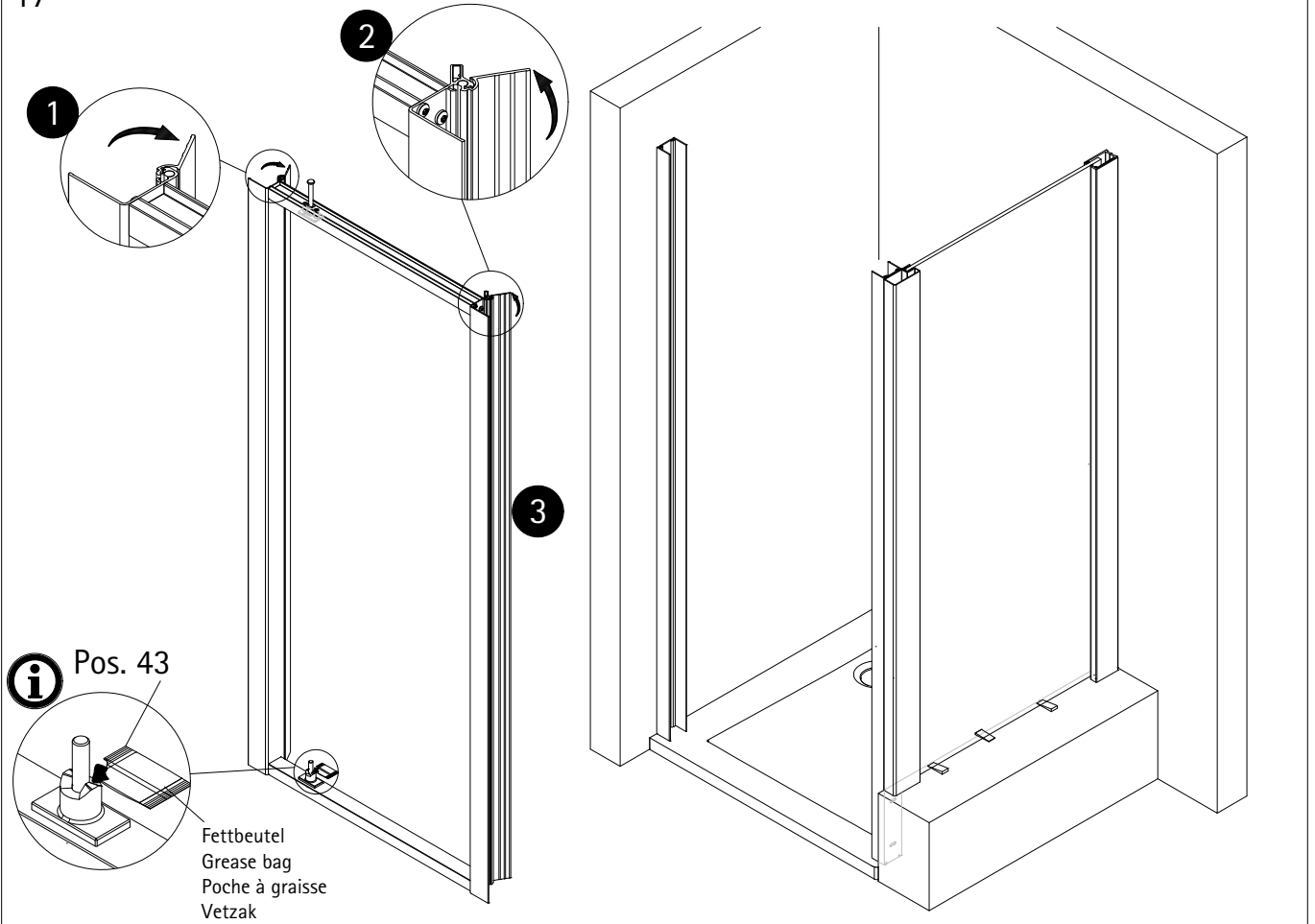

18

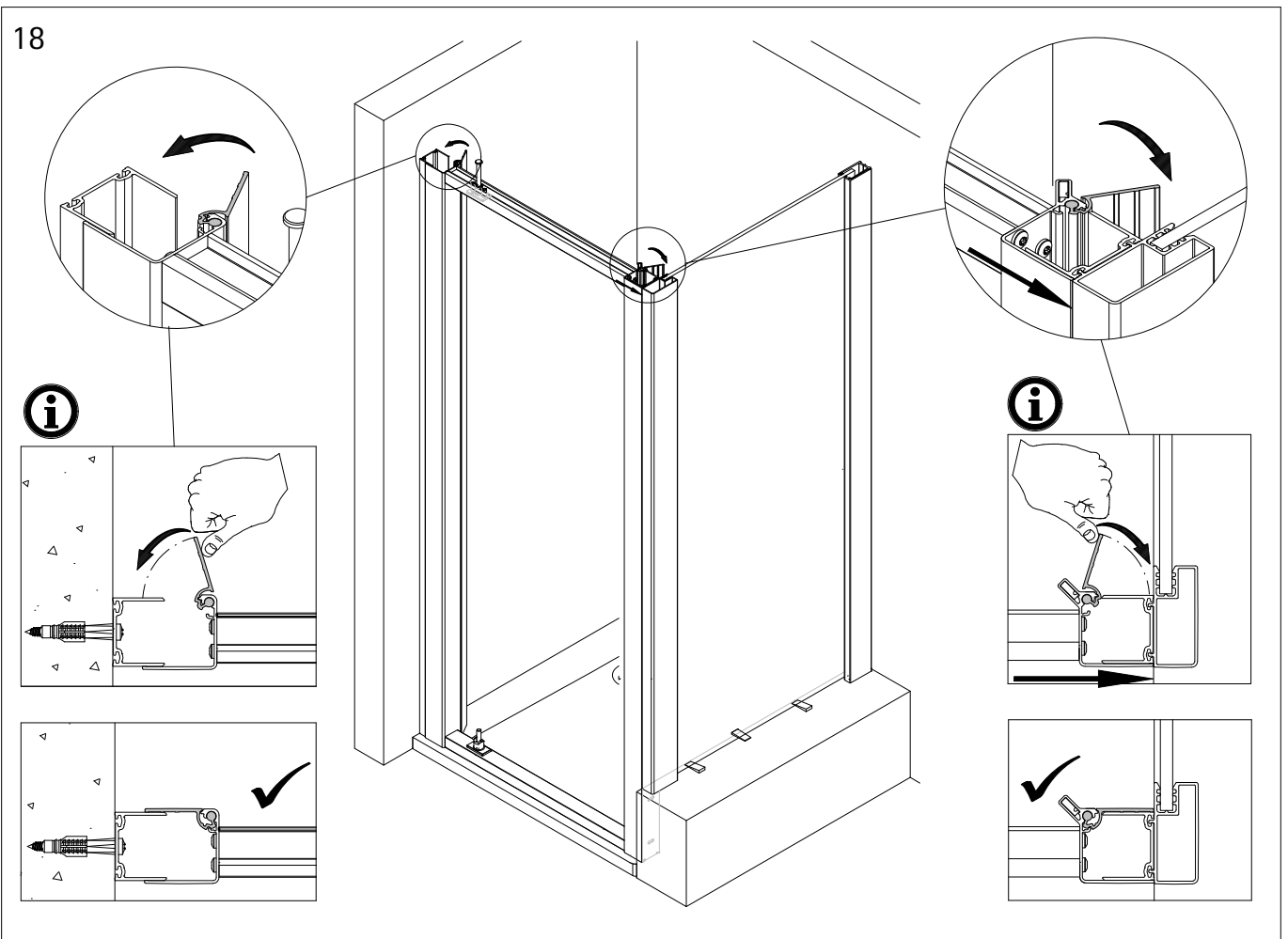

19

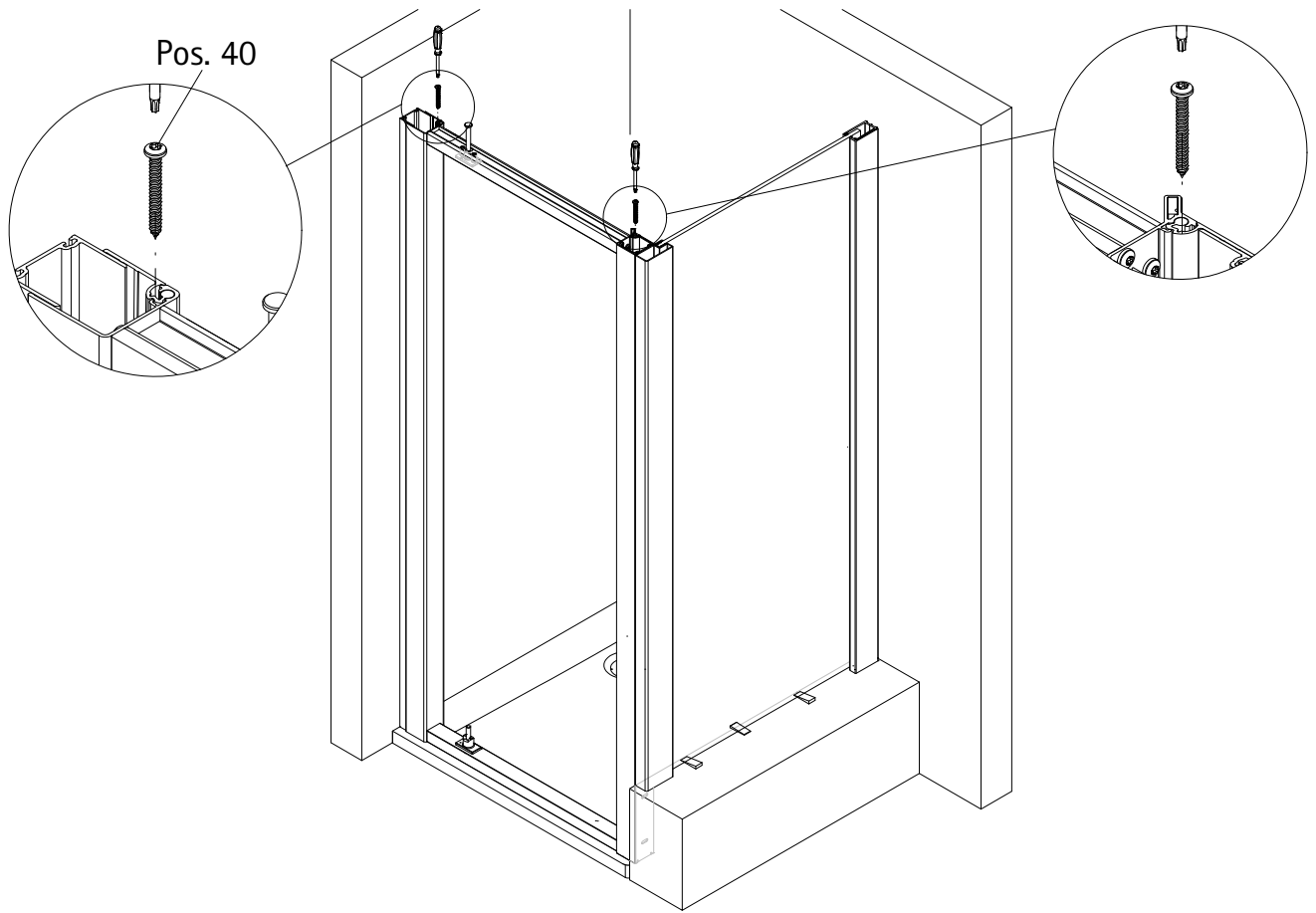

20

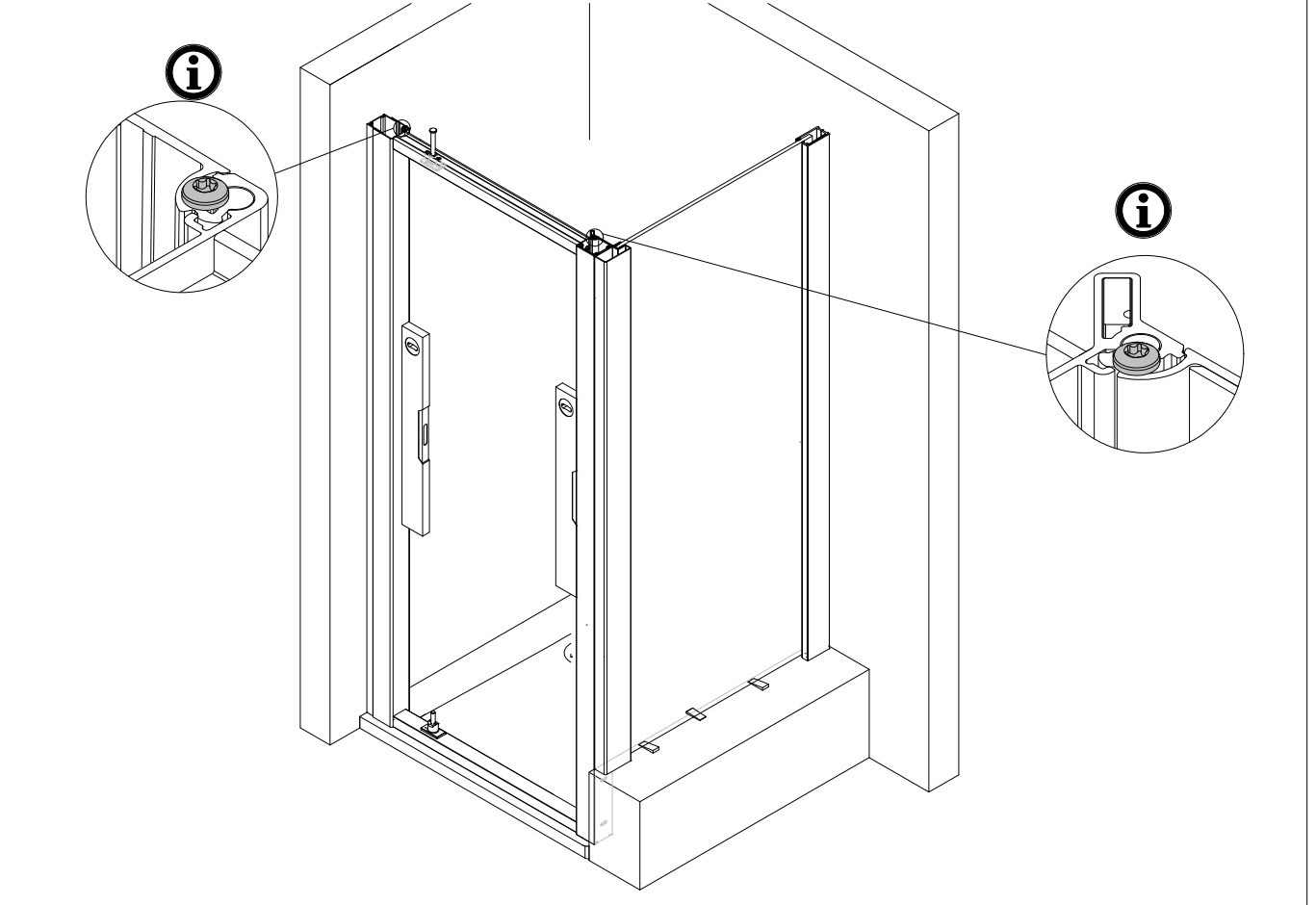

21

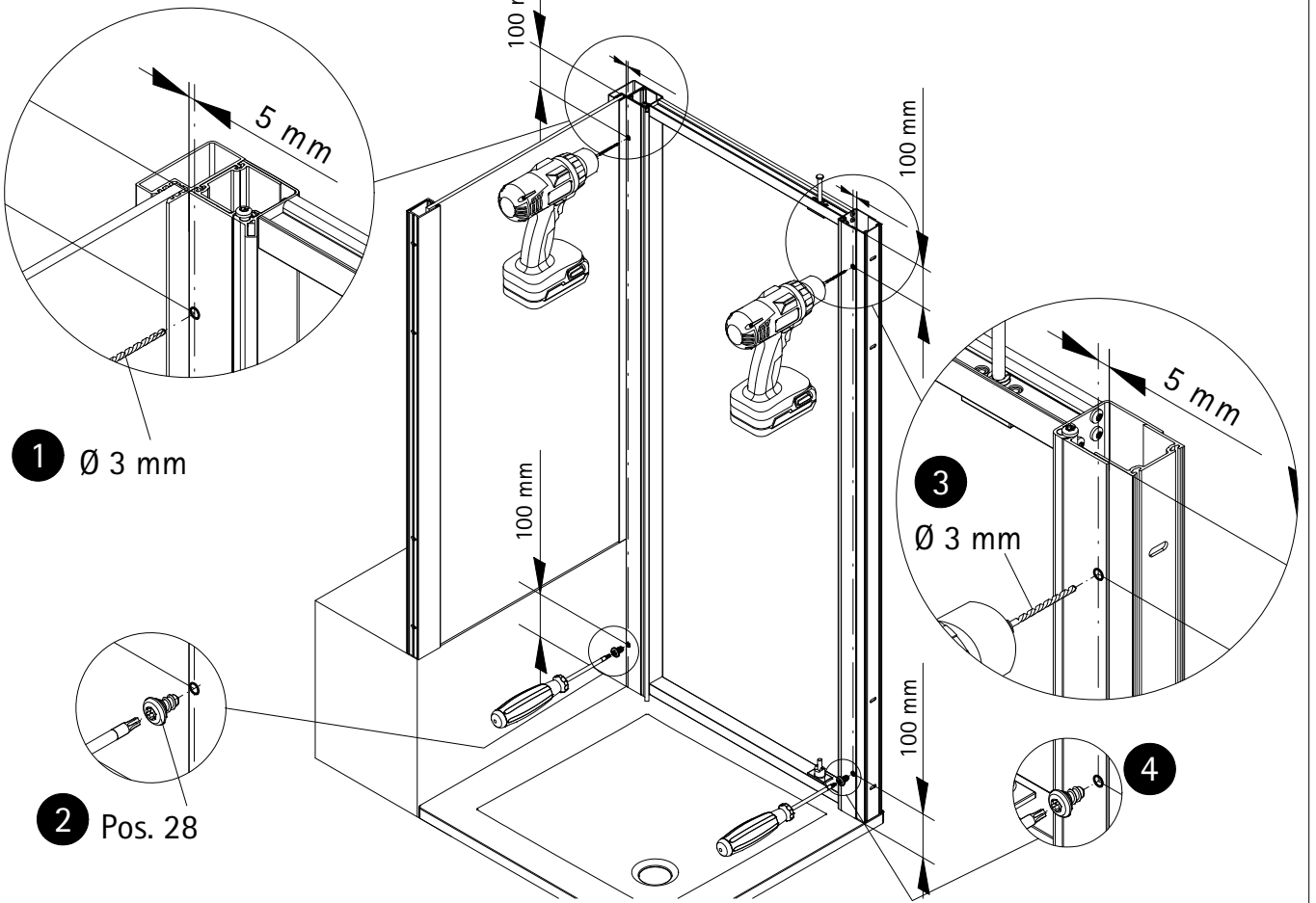

22

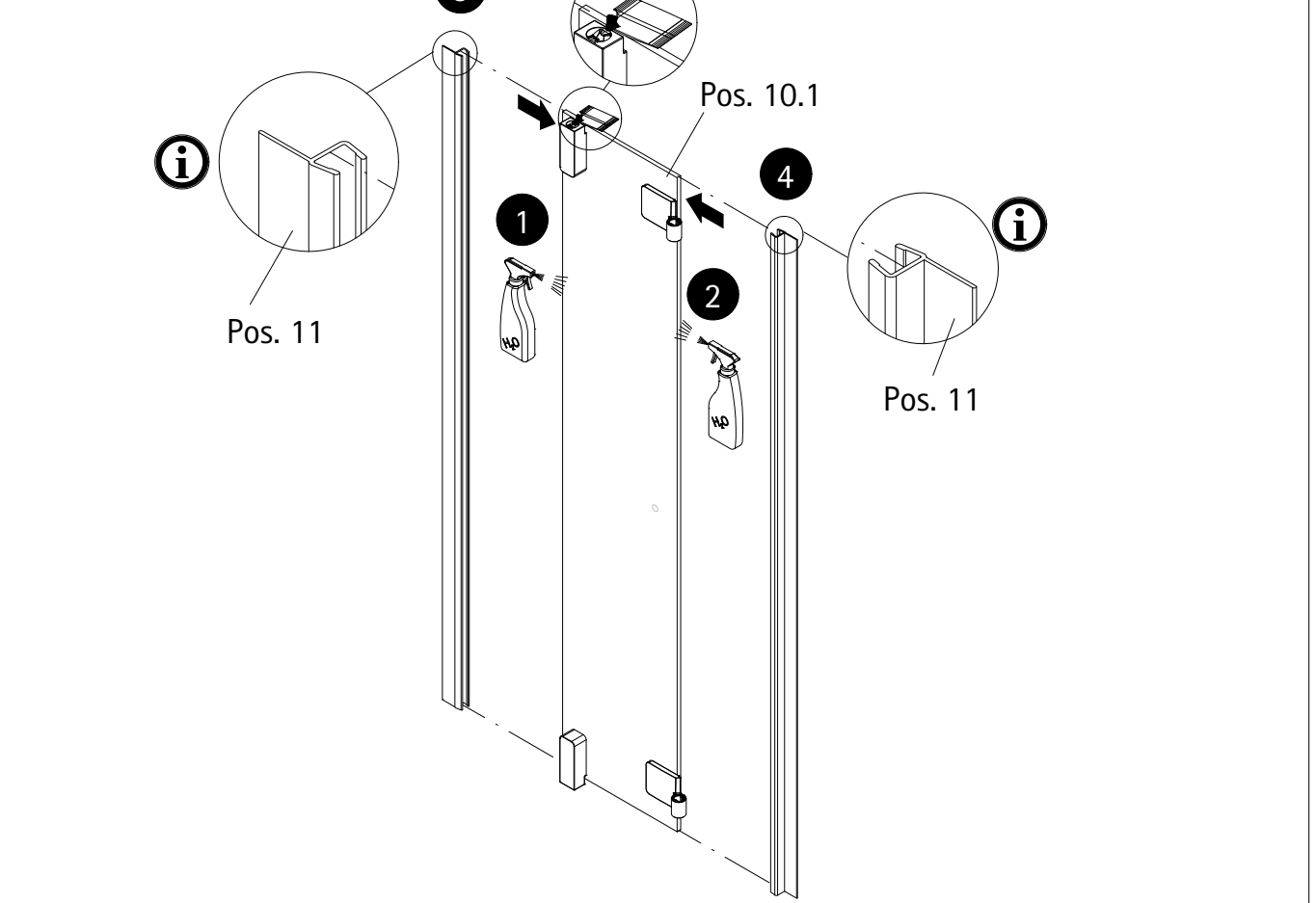

23

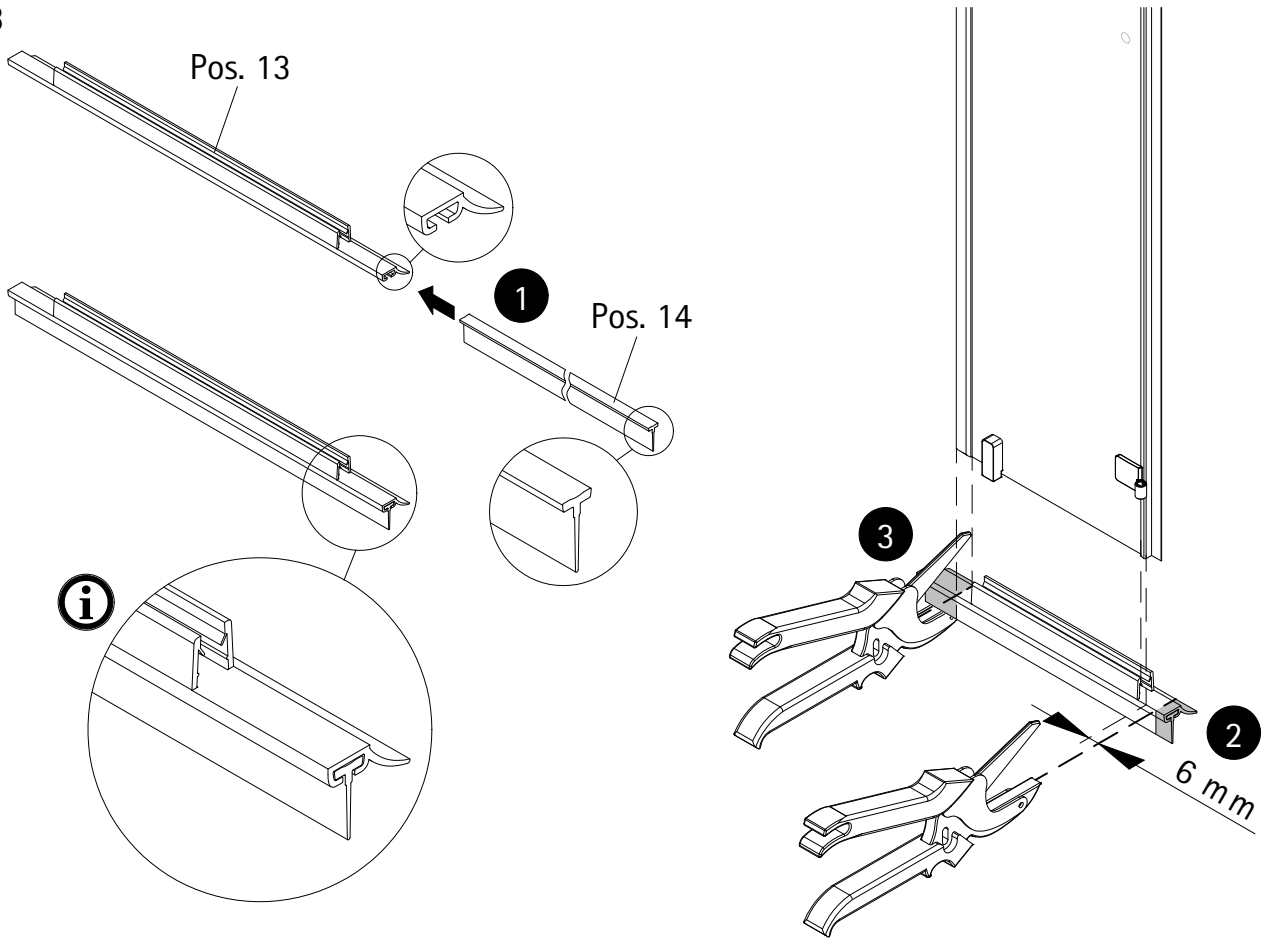

24

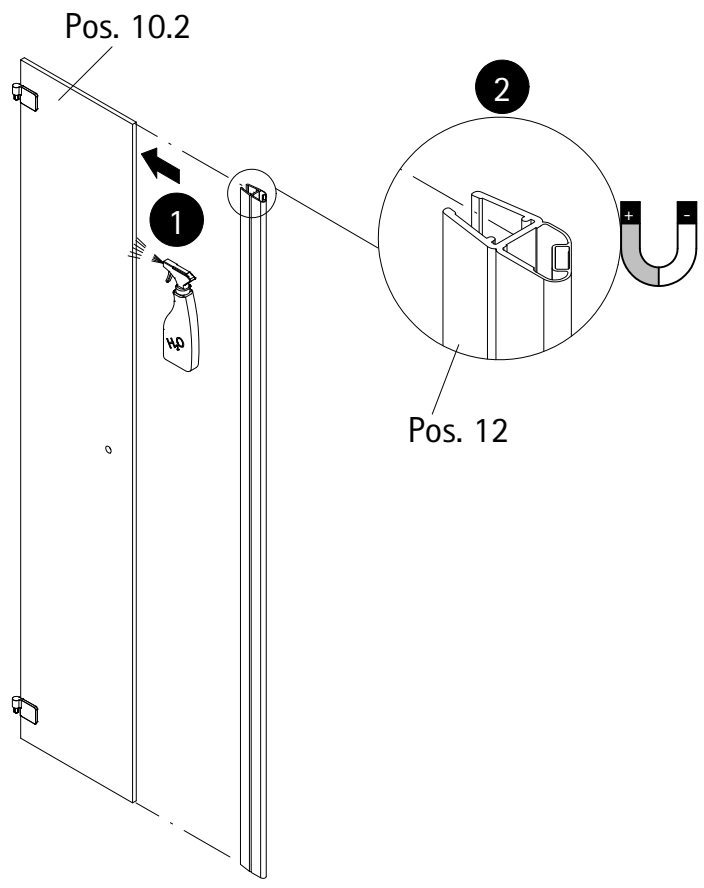

25

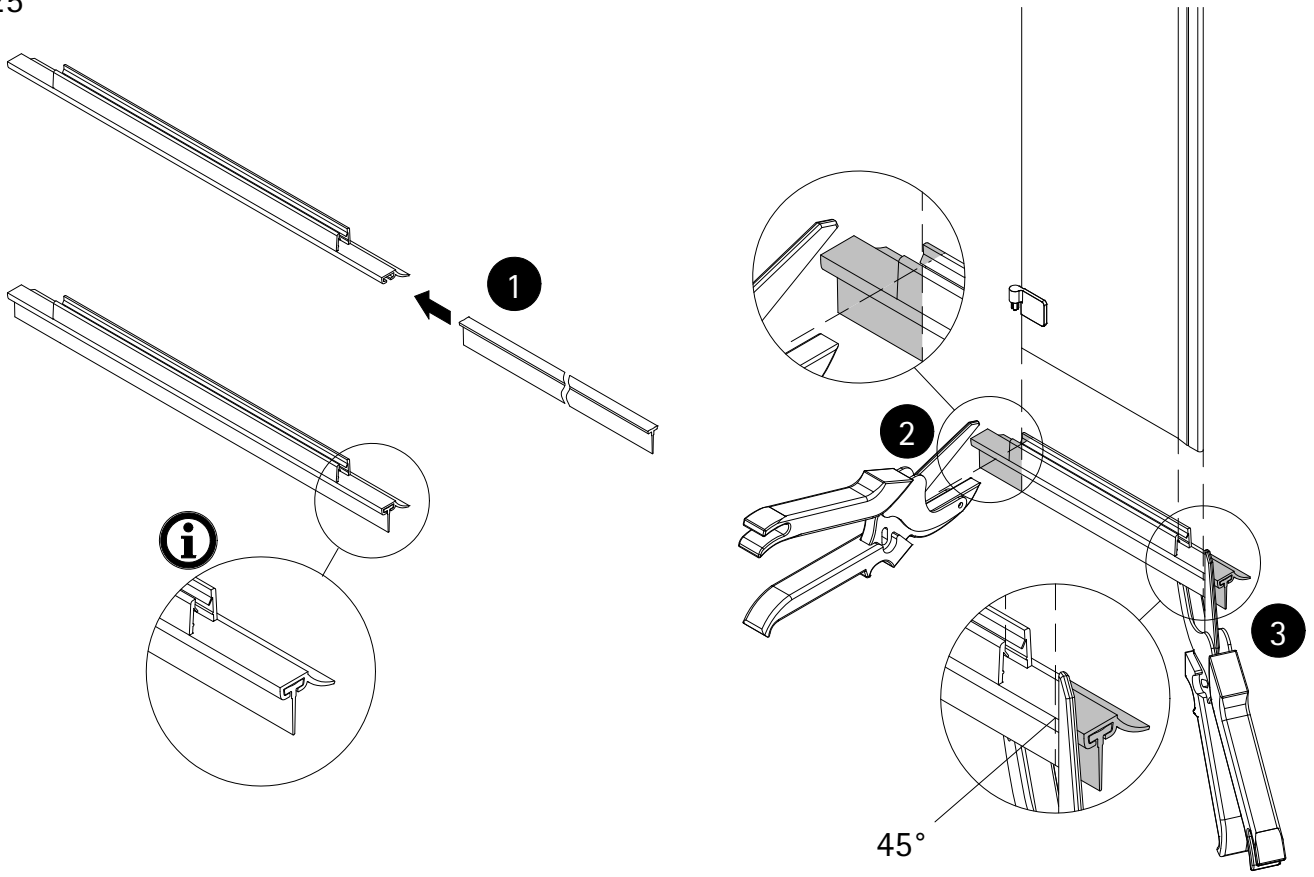

26

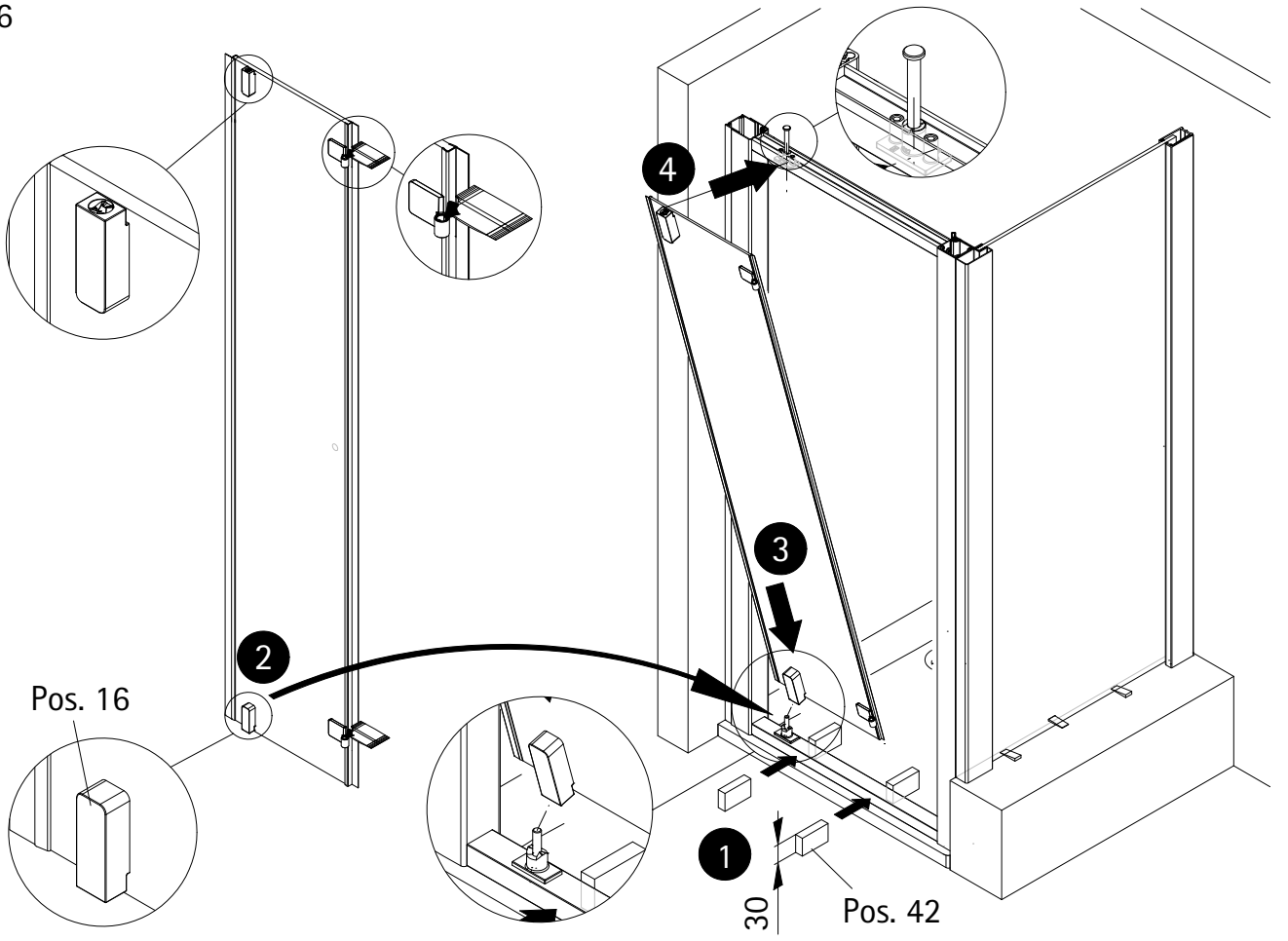

27

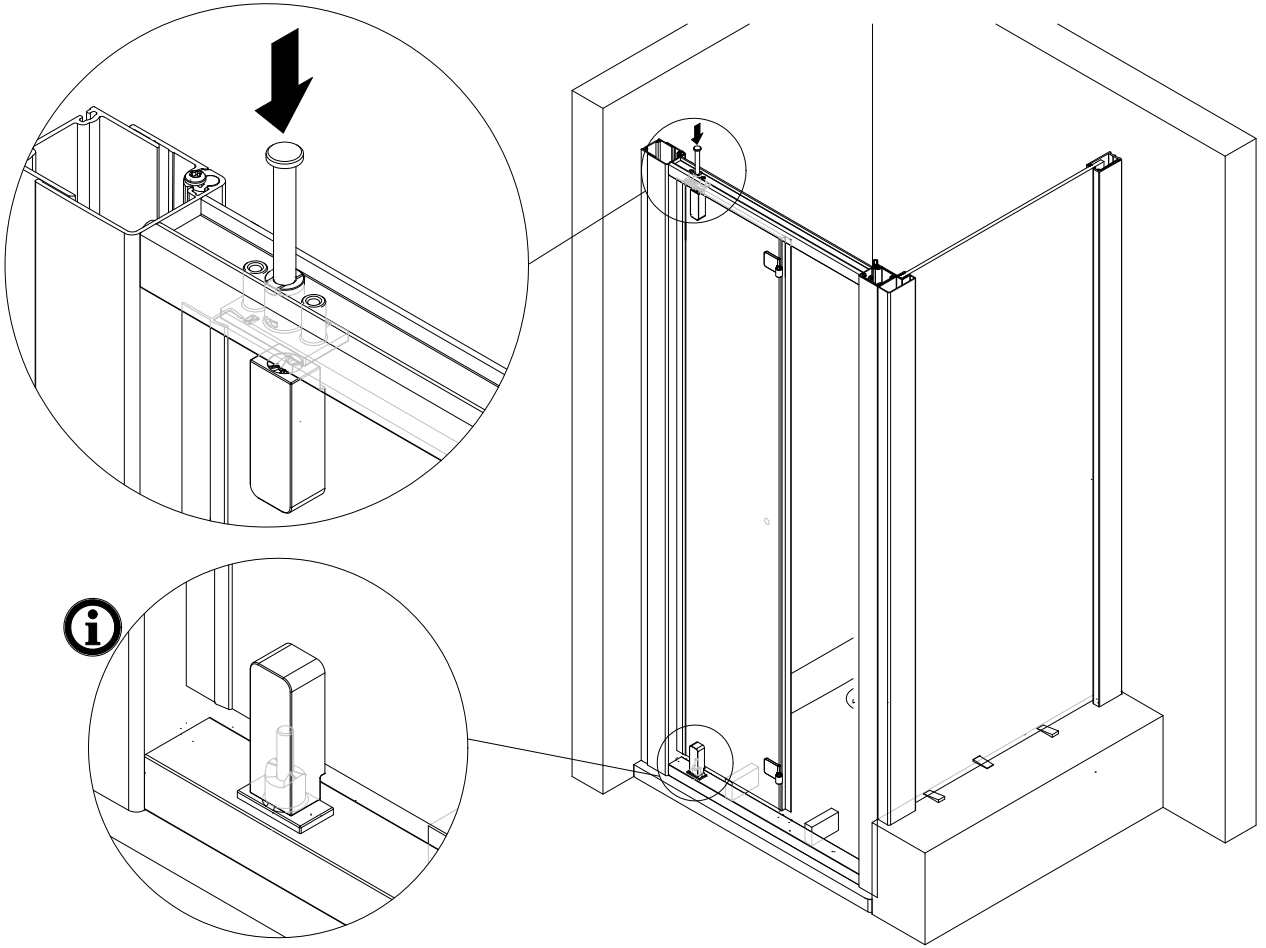

28

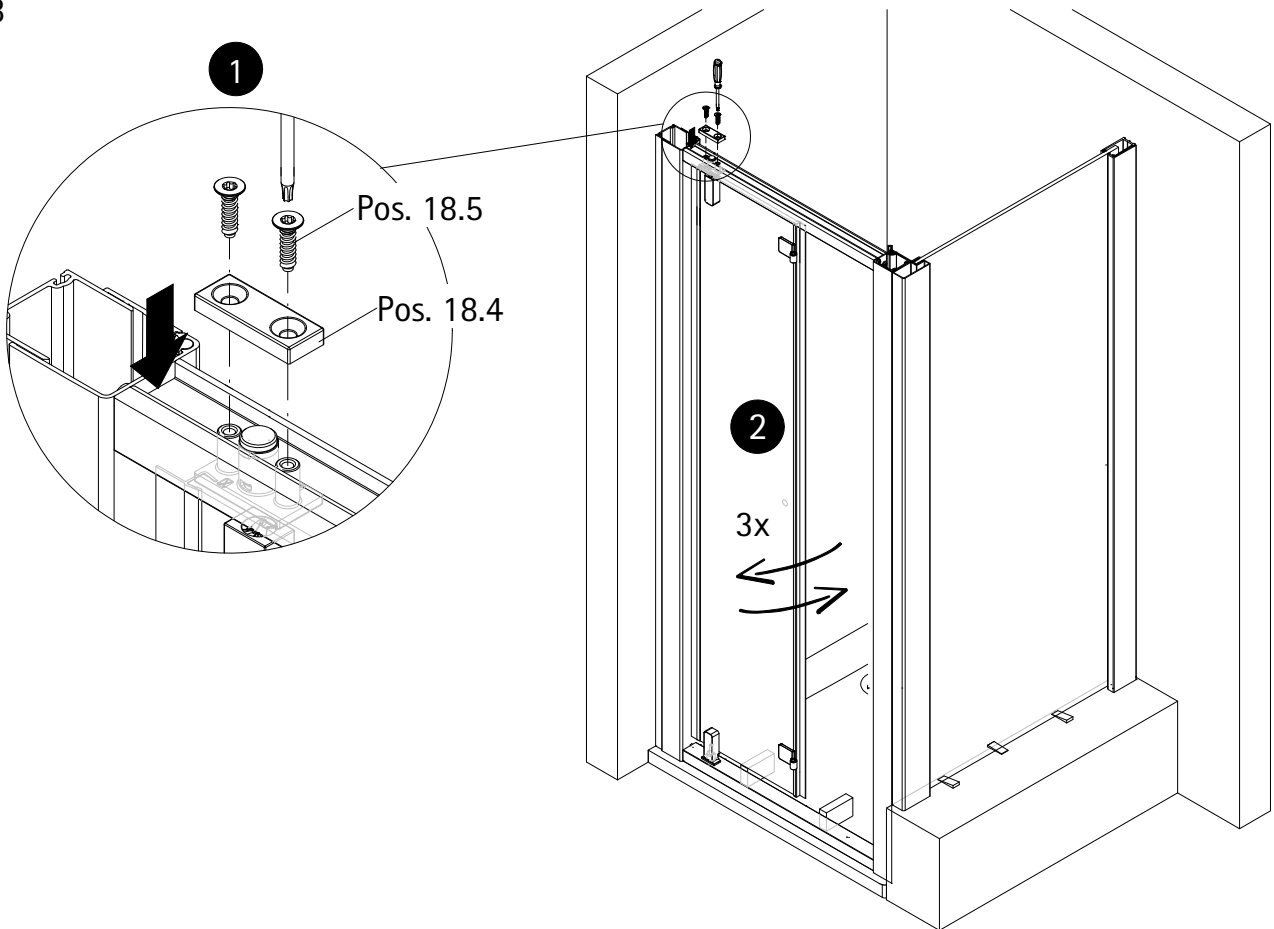

29

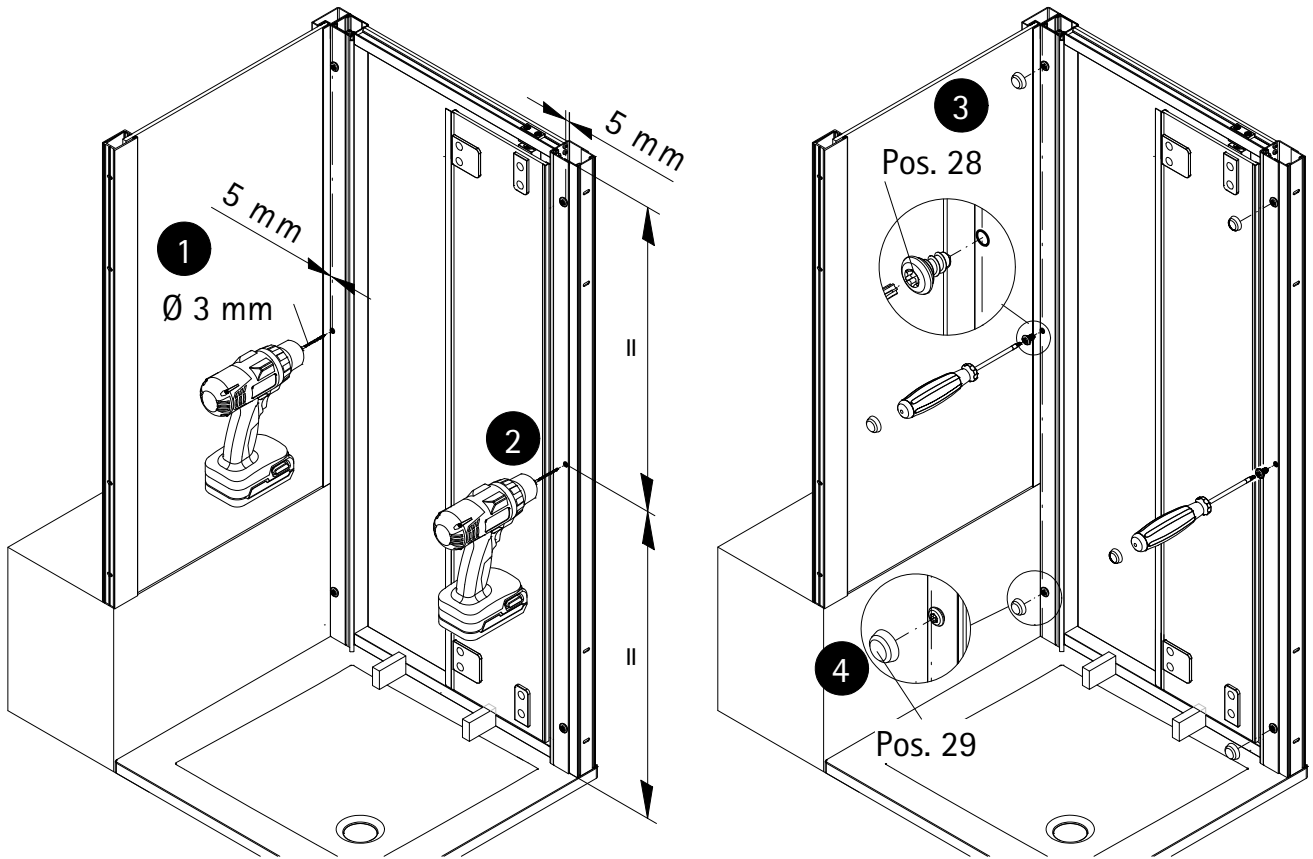

30

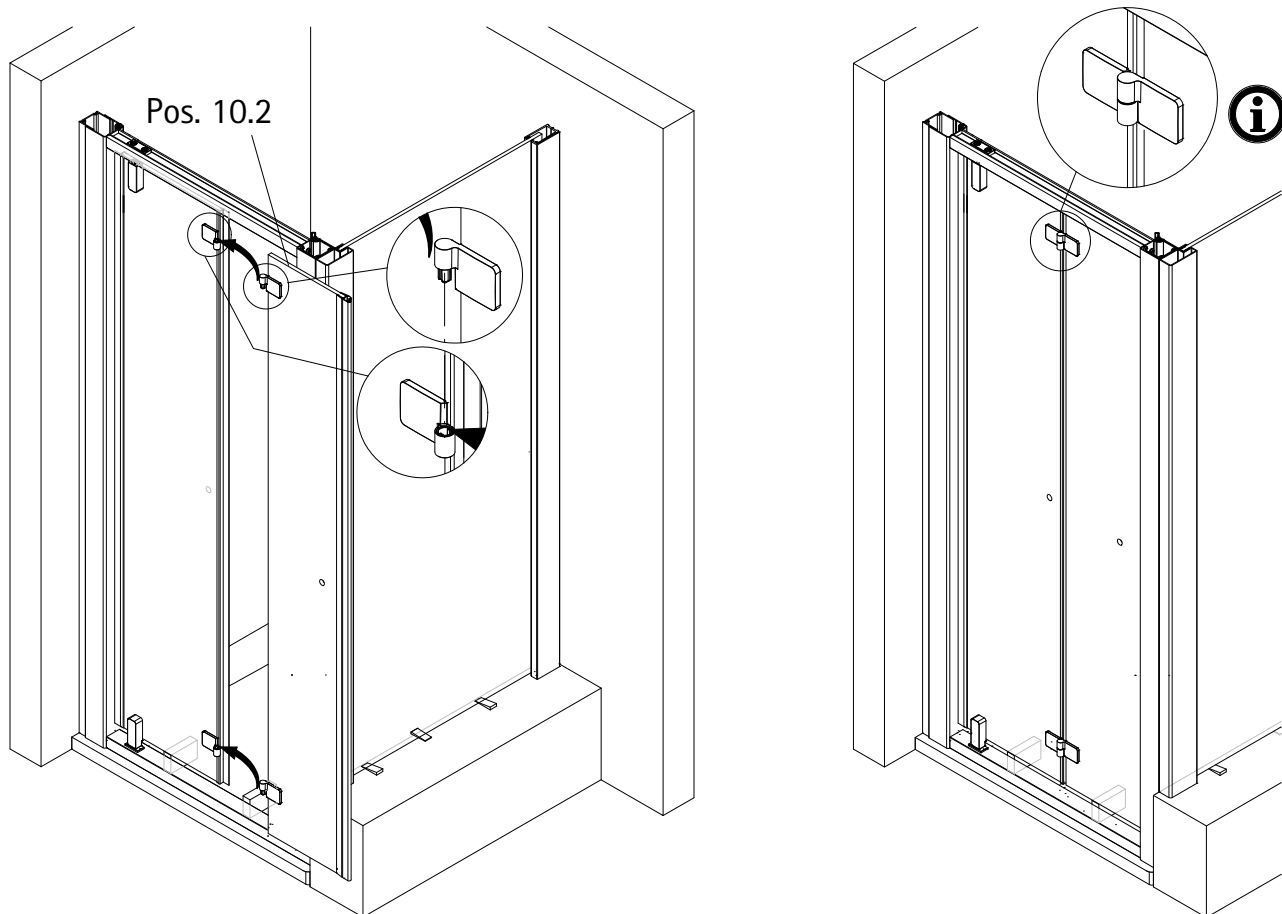

31

Wenn die Tür nicht parallel schließt:
 -die oberen Schrauben etwas lösen
 -ausrichten
 -Schraube festziehen.

If the door does not close in parallel:
 -slacken the upper screws a little
 -align
 -tighten the screws

Si la porte ne se ferme pas de manière parallèle:
 -desserrer légèrement les vis supérieures
 -aligner
 -serrer les vis

Als de deur niet parallel sluit:
 -de bovenste schroeven iets losser draaien
 -uitlijnen
 -draai de schroeven vast

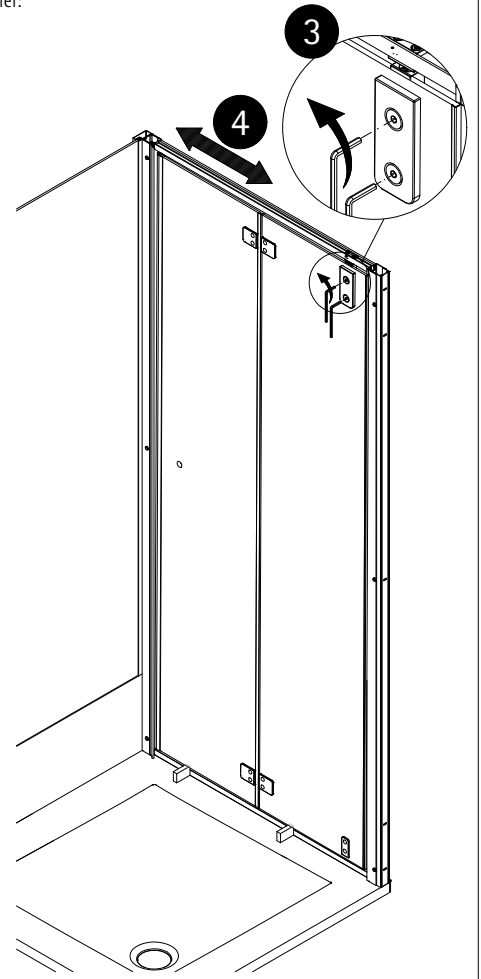
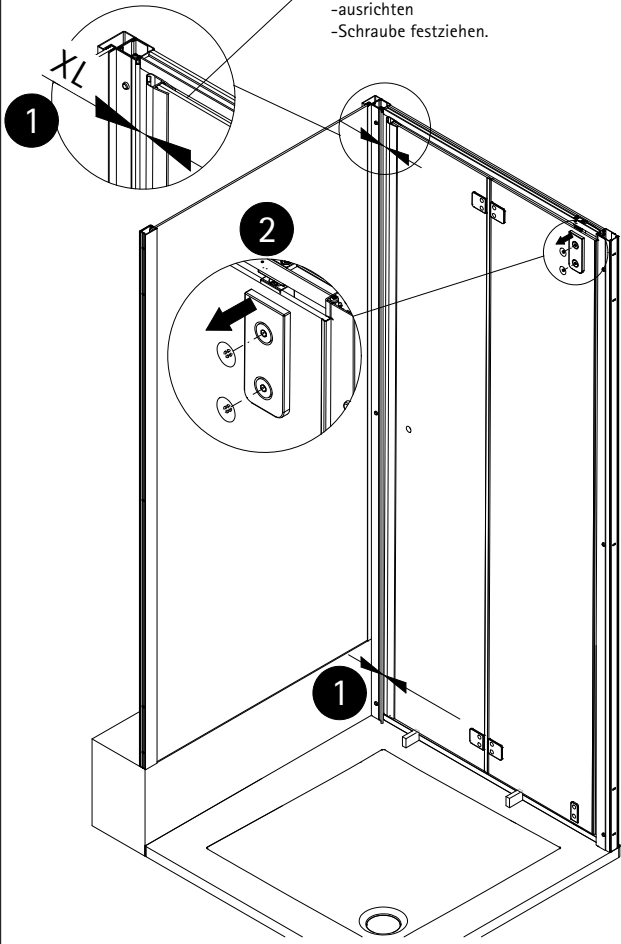

32

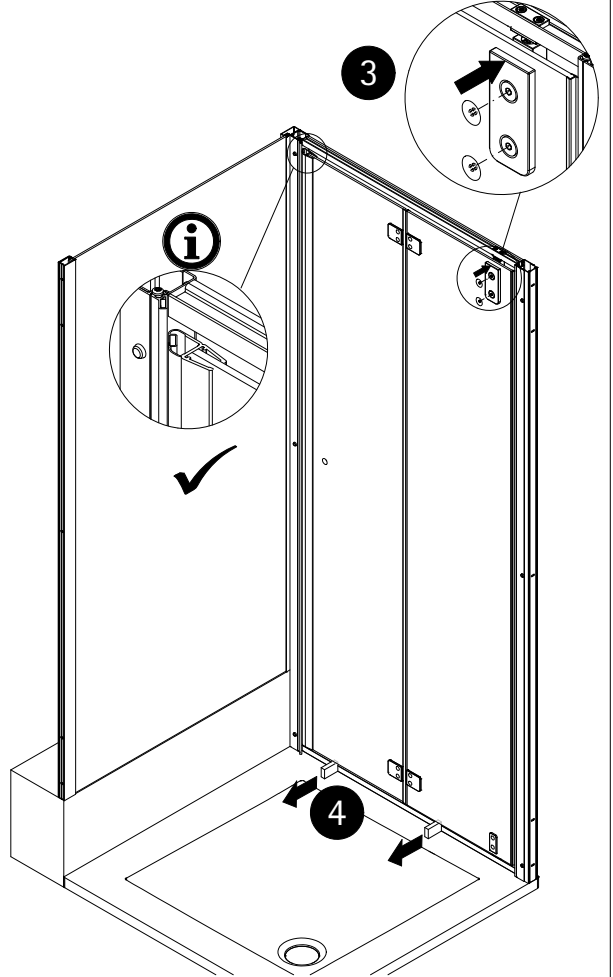
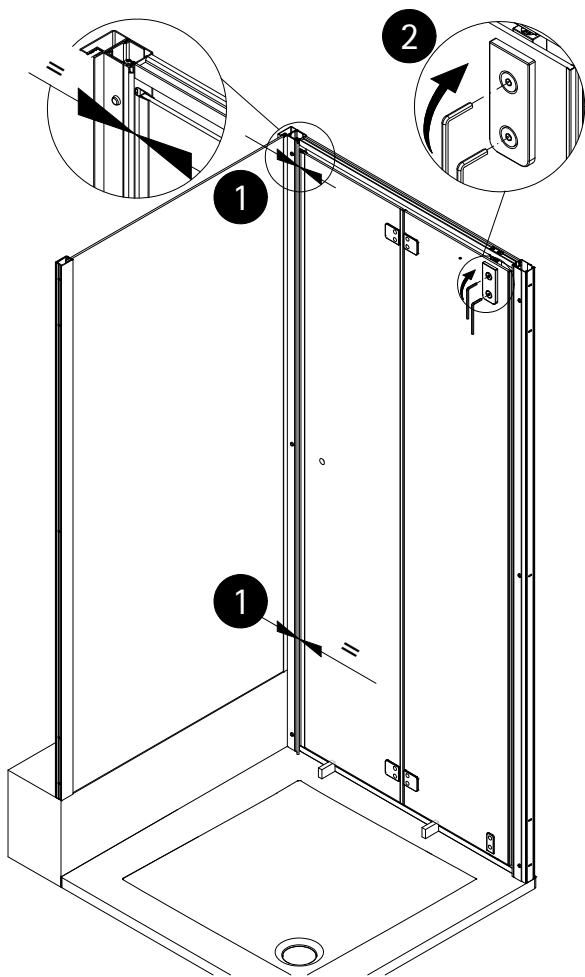

33

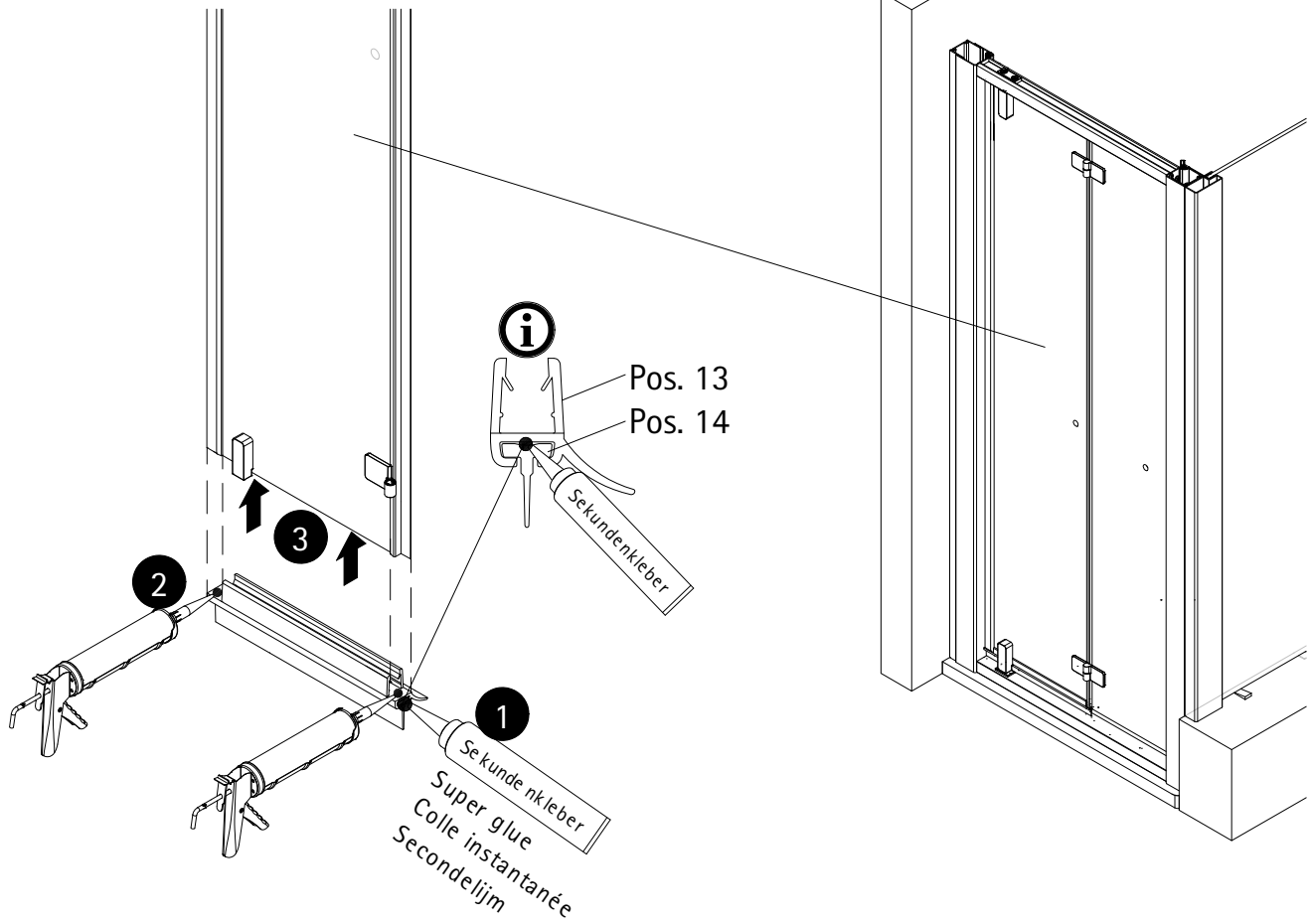

34

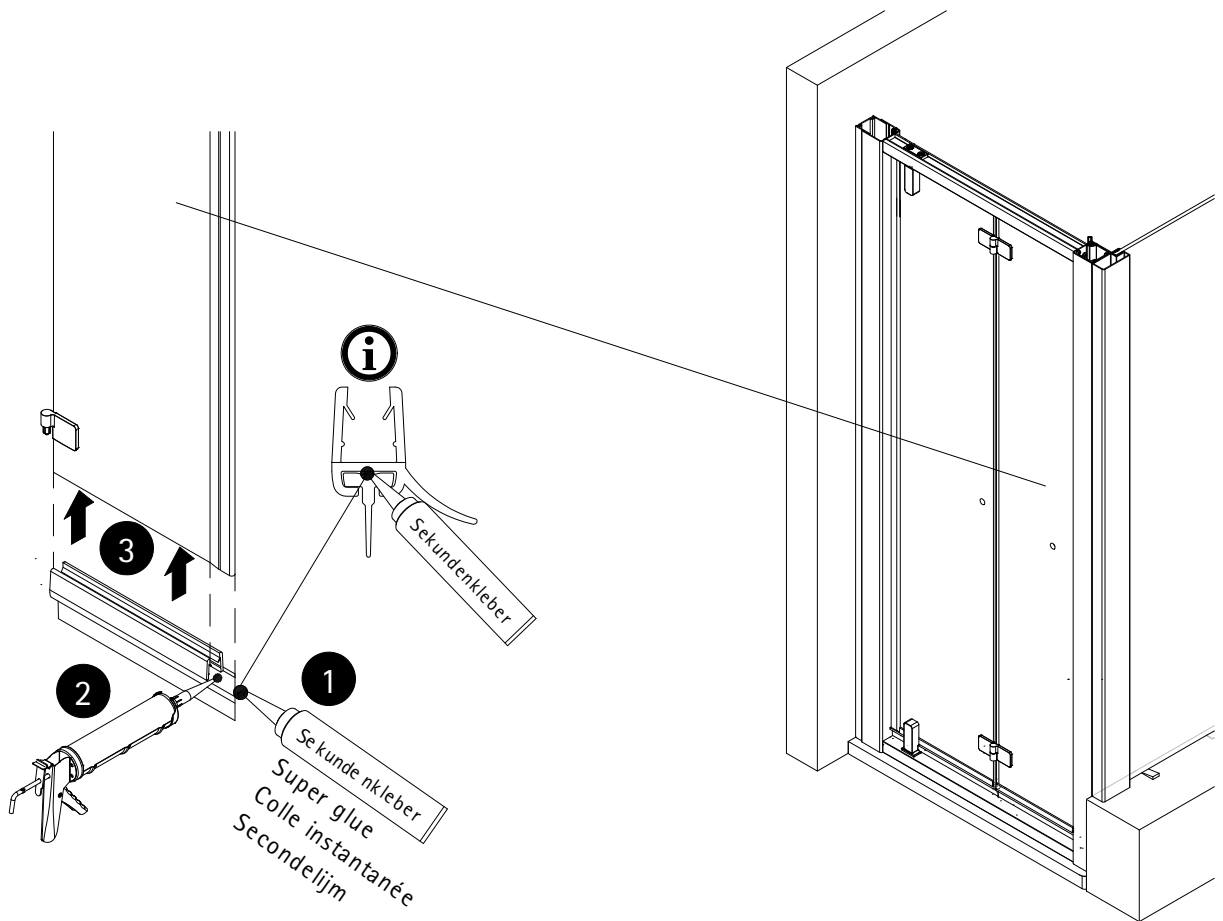

35

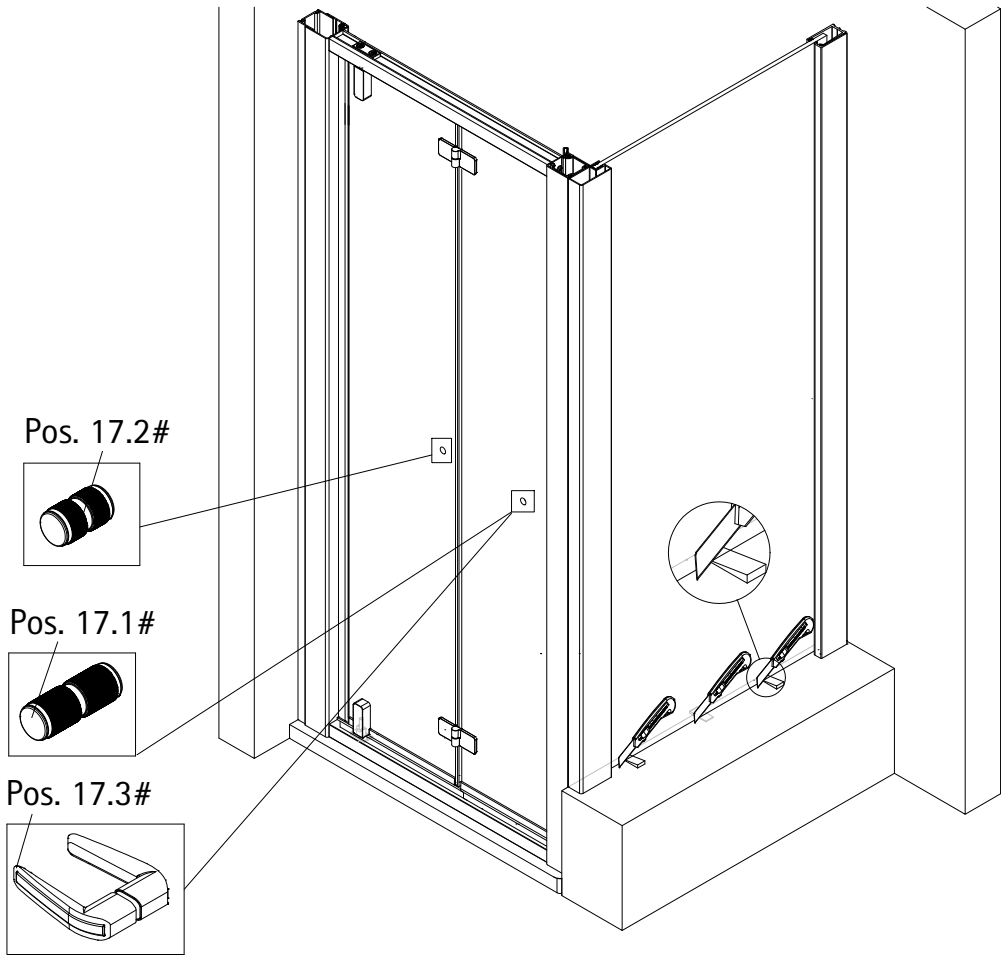

36

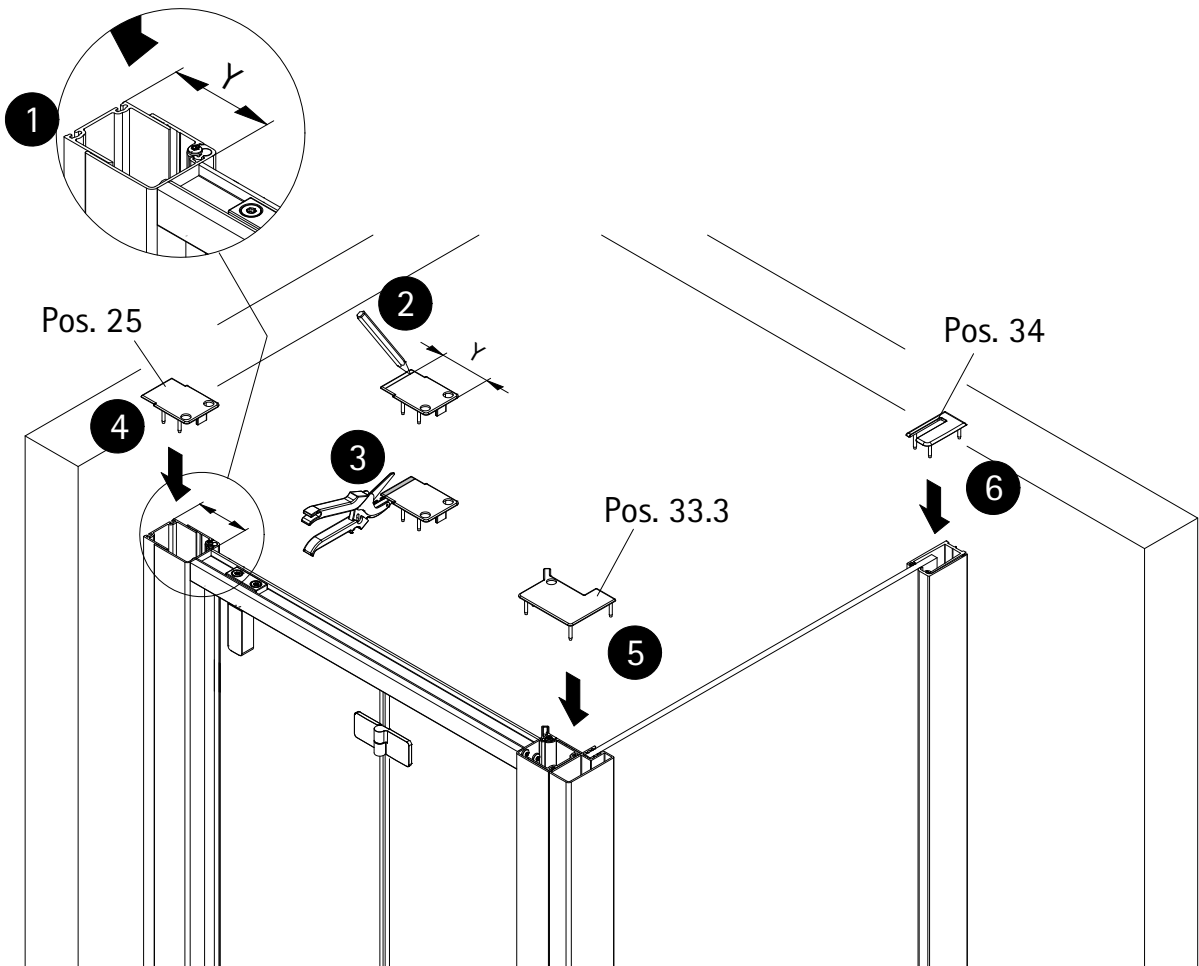

37

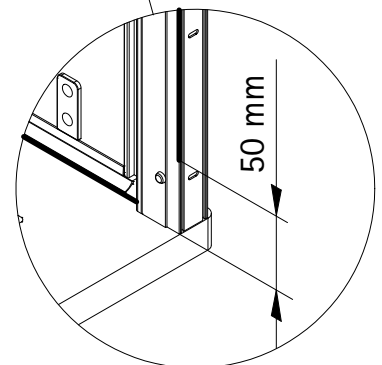
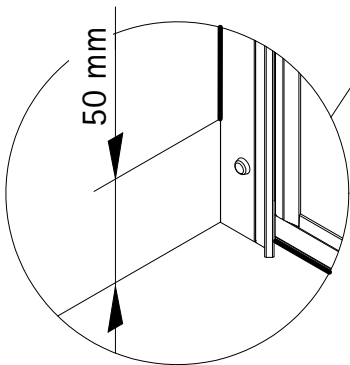
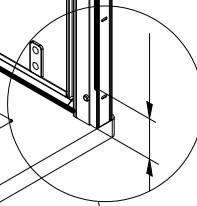
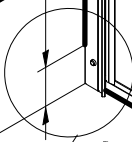
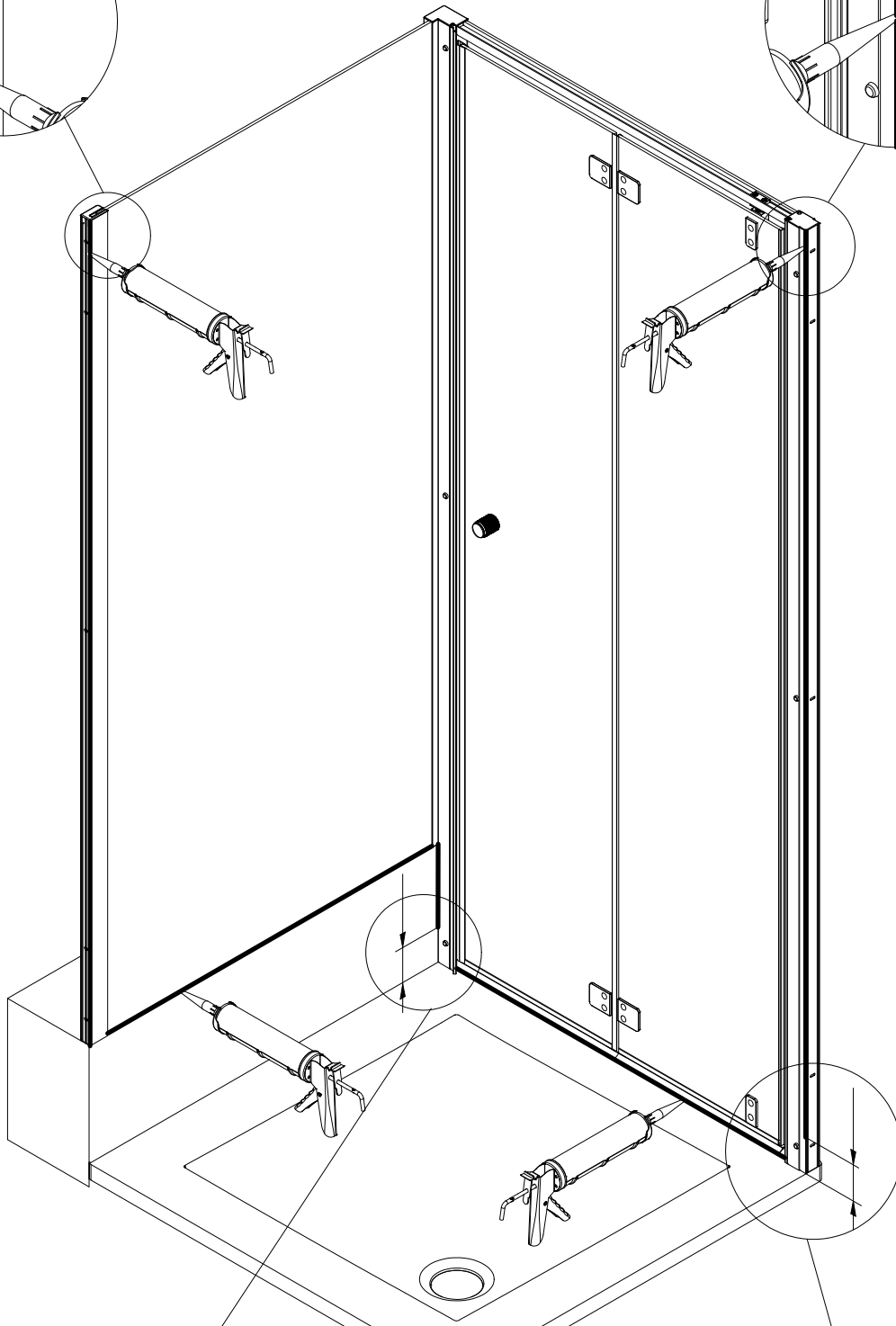
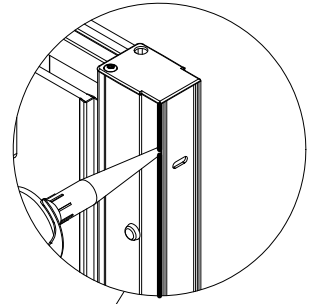
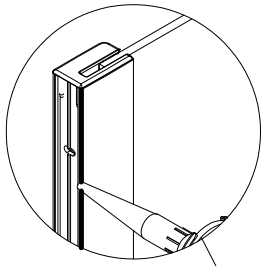

24 h

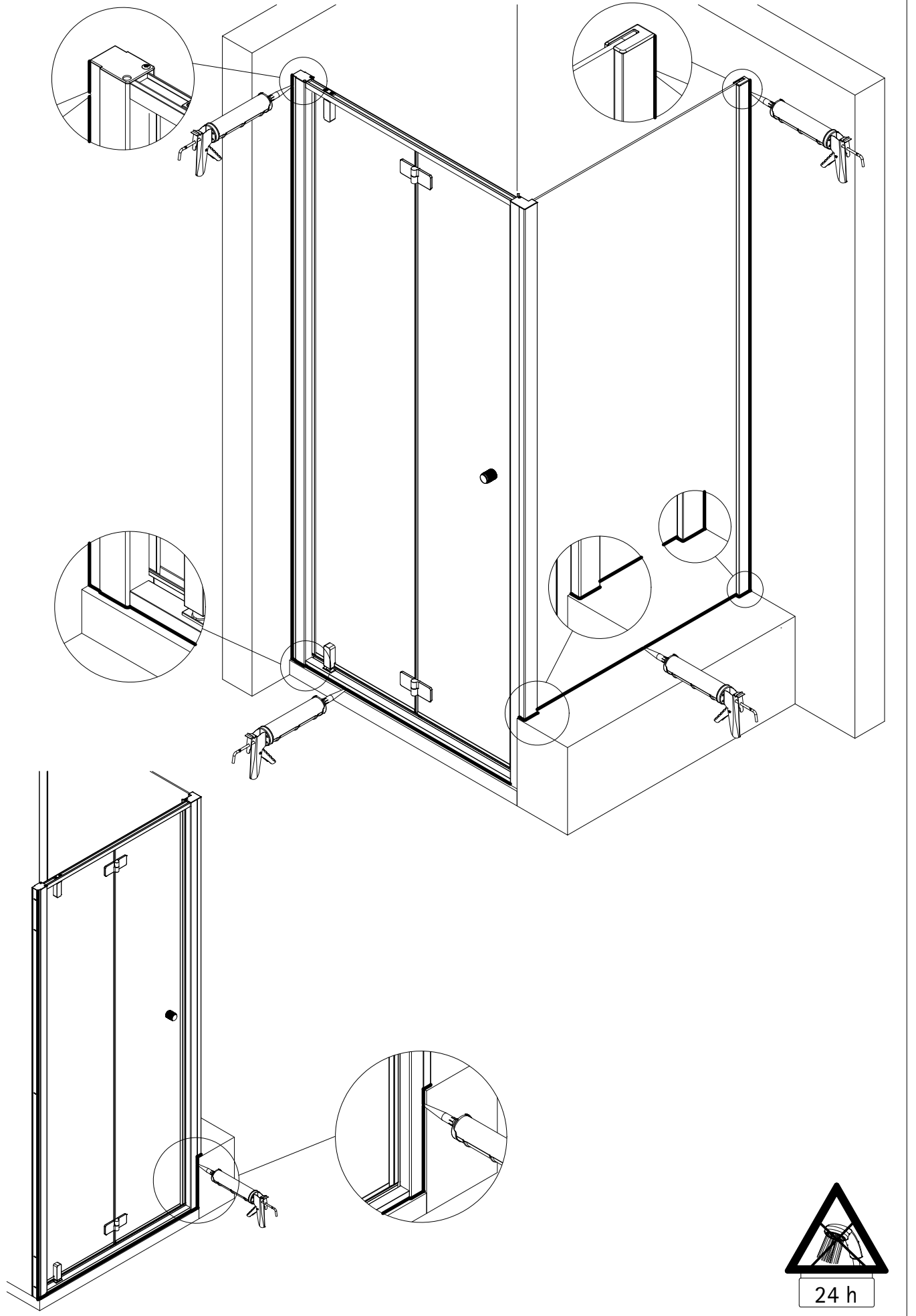



Hinweis Demontage/ Note for disassembly/ Remarque sur le démontage/ Informatie demontage

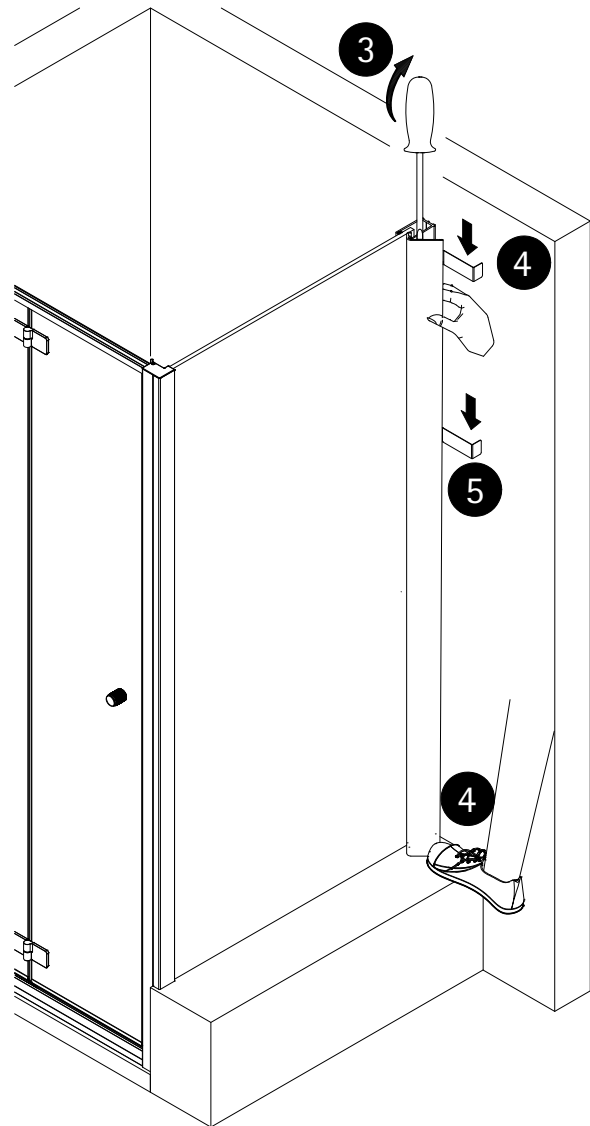
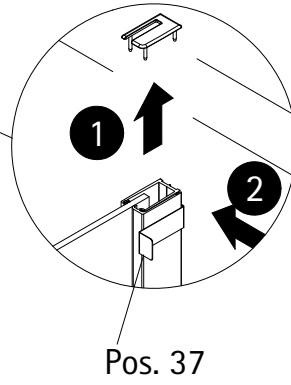
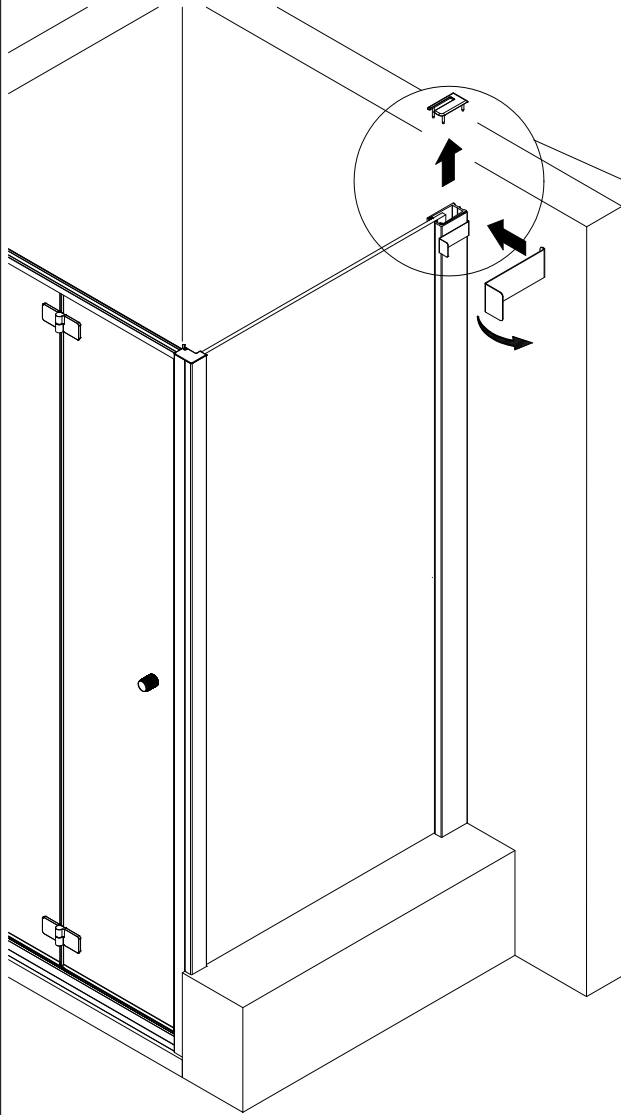

2162-2

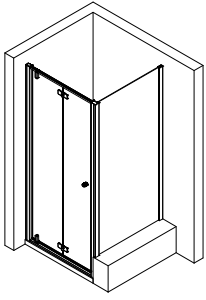

Prüfnummer / Inspection number / Numéro de contrôle / Testnummer



Ersatzteilbestellung / spare parts order
commande de pièces détachées / Bestelling van onderdelen:
Fax 02962 / 972-4260



Technische Hilfe / technical help / l'aide technique / technologische ondersteuning
Telefon 02962 / 972-40



E-Mail:
ersatzteile@duschservice.de



Duschservice
Zum Hohlen Morgen 22
59939 Olsberg
Deutschland / Germany / Allemagne / Duitsland

